

**Experimental Guideline**  
**for**  
**Vehicle Communications System using 700 MHz-Band**

**ITS FORUM RC-006 Version 1.0**

**Established on February 12, 2009**

**ITS Info-communications Forum**

**of Japan**



**Experimental Guideline**  
**for**  
**Vehicle Communications System using 700 MHz-Band**

**ITS FORUM RC-006 Version 1.0**

**Established on February 12, 2009**

**ITS Info-communications Forum**  
**of Japan**



[Blank]

---

## Preface

This document takes over the “Experimental Guideline for Inter-Vehicle Communications System using 5.8 GHz-Band,” (ITS FORUM RC-005), and considers the specifications for radio communications that use a new frequency band (700 MHz) with the aim of further upgrading the aforementioned guideline. We hope that various activities, e.g., large-scale demonstration tests, toward the standardization of vehicle communications systems will be encouraged in the course of verifying the communication specifications in this guideline.

### (1) Background

Since the fiscal year 2006, the Vehicle Communications System Expert Group (formerly Inter-Vehicular Communications System Expert Group) has been studying communication specifications and promoting standardization activities for a new inter-vehicle communications system while proposing various radio communication schemes. Concurrently, the technological considerations were mainly intended for the inter-vehicle communications system using 700 MHz-Band; the application requirements were considered in collaboration with the Study Group for Promotion of ASV (Advanced Safety Vehicle). These activities have led us from the phase in which technological considerations were focused on feasible communication specifications to the phase in which experimentation and verification are conducted in real environments by installing on-board equipment in vehicles.

### (2) Objectives

This guideline specifies the radio communication interfaces of inter-vehicle communication using 700 MHz-Band, aiming for the standardization and contributing to the experiments on applications meant to assist safe driving.

### (3) Scope of guidelines and their orientation

This experimental guideline describes the vehicle communications systems that use the 700 MHz-Band.

The vehicle communications system based on inter-vehicle communications requires high-speed transmission in addition to high tolerance toward multipath propagation and delay spread. Taking these requirements into consideration, the radio communication scheme specified in this guideline has been developed with reference to Layer 1 and Layer 2 of the ARIB STD-T71, in which orthogonal frequency division multiplexing (OFDM), which is considered to be appropriate for satisfying such requirements, is adopted; in Layer 7, a suitable scheme for vehicle communications has been adopted.

The scope of application has been determined on the basis of the “Specifications of system concept for inter-vehicle communication type driver assistance (Version 1.0)” and the “Definitions of system for

---

inter-vehicle communication type driver assistance (Version 1.0)” established by the Fourth Study Group for Promotion of ASV.

(4) Technical Preconditions

This guideline describes the technical conditions for radio equipment and the specifications for Layer 1, Layer 2, and Layer 7, which should be satisfied for land mobile stations (on-board equipment) meant for 700 Hz-Band vehicle communications. These schemes, specifications, and technical conditions are based on the results considered by the Vehicle Communications System Expert Group.

(5) Use of this document

This guideline assumes a particular design of land mobile stations (on-board equipment) for the experiments involving vehicle communications systems that use the 700 MHz-Band. However, the installation procedure or the system verification method for the experiments performed by actually installing the equipment in vehicles are not included.

**Experimental Guideline**  
for  
Vehicle Communications System using 700 MHz-Band

Table of Contents

|  |   |
|--|---|
| Chapter 1: General Descriptions .....                    | 1 |
| 1.1 Overview .....                                       | 1 |
| 1.2 Scope of this guideline.....                         | 1 |
| 1.3 Guideline Principles .....                           | 2 |
| 1.4 References.....                                      | 2 |
| 1.4.1 Normative References .....                         | 2 |
| 1.4.2 Informative References.....                        | 2 |
| Chapter 2: System Overview .....                         | 4 |
| 2.1 System Configuration.....                            | 4 |
| 2.1.1 On-board Equipment (OBE) .....                     | 4 |
| 2.2 Interface Definition .....                           | 4 |
| 2.3 Basic Functions of the System.....                   | 4 |
| 2.3.1 System Conditions .....                            | 4 |
| 2.3.1.1 Basic Functions.....                             | 4 |
| 2.3.2 Services provided by this system .....             | 5 |
| 2.3.2.1 Service types.....                               | 5 |
| 2.4 Access Control .....                                 | 6 |
| 2.4.1 Transmission Scheme.....                           | 6 |
| 2.4.2 Radio Link Control .....                           | 6 |
| 2.5 Protocol .....                                       | 7 |
| 2.5.1 Protocol Stack .....                               | 7 |
| 2.5.1.1 Features of Layer 1 .....                        | 7 |
| 2.5.1.2 Features of Layer 2 .....                        | 7 |
| 2.5.1.3 Features of Layer 7 .....                        | 8 |
| 2.5.2 Numbering Plan (addressing).....                   | 8 |
| 2.6 Security Measures .....                              | 8 |
| Chapter 3: Technical Conditions for Radio Equipment..... | 9 |
| 3.1 Overview .....                                       | 9 |

|   |    |
|---|----|
| 3.2 General Conditions.....   | 9  |
| 3.3 Transmitter.....  | 9  |
| 3.4 Receiver.....   | 11 |
| 3.5 Controller.....   | 11 |
| 3.5.1 Interference Rejection .....  | 12 |
| 3.6 Antenna .....   | 12 |
| 3.7 Clear channel assessment (CCA) method, technical conditions for carrier sense .....   | 12 |
| 3.8 Miscellaneous.....  | 12 |
| 3.8.1 Cabinet.....  | 12 |
| 3.8.2 Security measures .....   | 13 |
| 3.8.3 Countermeasures against electromagnetic interference.....                           | 13 |
| Chapter 4: Communication Control.....   | 14 |
| 4.1 Overview .....  | 14 |
| 4.1.1 Overview of layers, layer management, and services between system managements ..... | 14 |
| 4.2 Standard for Layer 1.....   | 14 |
| 4.2.1 Overview .....  | 14 |
| 4.2.2 Features of Services .....  | 14 |
| 4.2.2.1 Service access point.....   | 14 |
| 4.2.2.2 Services provided by Layer 1 .....  | 14 |
| 4.2.2.2.1 Transmission capacity.....  | 14 |
| 4.2.2.2.2 Start/stop.....   | 15 |
| 4.2.2.2.3 Maintenance and status indication.....  | 15 |
| 4.2.3 Communication Frame .....   | 15 |
| 4.2.3.1 Structure of communication frame.....   | 15 |
| 4.2.3.1.1 MAC header .....  | 15 |
| 4.2.3.1.1.1 Frame control field.....  | 16 |
| 4.2.3.1.1.2 Duration ID field.....  | 16 |
| 4.2.3.1.1.3 Address 1 field.....  | 16 |
| 4.2.3.1.1.4 Address 2 field.....  | 16 |
| 4.2.3.1.1.5 Sequence control field .....  | 17 |
| 4.2.3.1.1.6 Address 3 and Address 4 fields.....   | 17 |
| 4.2.3.1.2 Experimental MAC header .....   | 17 |
| 4.2.3.1.3 FCS field.....  | 17 |
| 4.2.3.1.4 Bit transmission sequence .....   | 17 |
| 4.2.4 PLCP frame format.....  | 17 |

---

|   |    |
|---|----|
| 4.2.4.1 Overview of the PPDU encoding process .....                     | 17 |
| 4.2.4.2 RATE-dependent parameters .....                                 | 18 |
| 4.2.4.3 Timing related parameters .....                                 | 18 |
| 4.2.4.4 PLCP preamble (SYNC) .....                                      | 18 |
| 4.2.4.5 Signal field (SIGNAL) .....                                     | 18 |
| 4.2.4.5.1 Data rate (RATE) .....  | 18 |
| 4.2.4.5.2 PLCP length field (LENGTH) .....                              | 18 |
| 4.2.4.5.3 Parity (P), reserved (R), and signal tail (SIGNAL TAIL) ..... | 18 |
| 4.2.4.6 DATA field.....   | 18 |
| 4.2.4.6.1 Service field (SERVICE) .....                                 | 18 |
| 4.2.4.6.2 PPDU tail bit field (TAIL).....                               | 19 |
| 4.2.4.6.3 Pad bits (PAD).....   | 19 |
| 4.2.4.6.4 PLCP DATA scrambler and descrambler .....                     | 19 |
| 4.2.4.6.5 Convolutional encoder .....                                   | 19 |
| 4.2.4.6.6 Data interleaving .....                                       | 19 |
| 4.2.4.6.7 Subcarrier modulation mapping .....                           | 19 |
| 4.2.4.6.8 Pilot subcarriers .....                                       | 19 |
| 4.2.4.6.9 OFDM modulation .....   | 19 |
| 4.2.4.7 Clear channel assessment (CCA).....                             | 19 |
| 4.2.4.8 PLCP data modulation and modulation rate change .....           | 20 |
| 4.2.5 Physical Medium Dependent (PMD) layer specifications .....        | 20 |
| 4.2.5.1 PMD operating specifications (general) .....                    | 20 |
| 4.2.5.2 Outline description .....                                       | 20 |
| 4.2.5.3 Slot time .....   | 21 |
| 4.2.5.4 Transmit and receive antenna port impedance.....                | 21 |
| 4.2.5.5 Transmit and receive operating temperature range.....           | 21 |
| 4.2.5.6 PMD transmit specifications .....                               | 21 |
| 4.2.5.6.1 Symbol clock frequency tolerance.....                         | 21 |
| 4.2.5.6.2 Modulation accuracy .....                                     | 21 |
| 4.2.5.6.3 Transmitter center frequency leakage .....                    | 21 |
| 4.2.5.6.4 Transmitter spectral flatness .....                           | 21 |
| 4.2.5.6.5 Transmitter modulation accuracy .....                         | 21 |
| 4.2.5.7 PMD receive specifications .....                                | 21 |
| 4.2.5.7.1 Receiver minimum input level sensitivity.....                 | 22 |

---

---

|  |    |
|--|----|
| 4.2.5.7.2 Adjacent channel rejection [reference].....        | 22 |
| 4.2.5.7.3 Non-adjacent channel rejection [reference] .....   | 22 |
| 4.2.5.7.4 Receive maximum input level.....                   | 22 |
| 4.2.5.7.5 CCA sensitivity.....                               | 22 |
| 4.2.6 PLCP transmit procedure.....                           | 22 |
| 4.2.7 PLCP receive procedure .....                           | 23 |
| 4.2.8 OFDM TXTIME calculation.....                           | 23 |
| 4.2.9 OFDM PHY characteristics .....                         | 23 |
| 4.3 Standard for Layer 2.....                                | 23 |
| 4.3.1 MAC sublayer .....                                     | 23 |
| 4.3.1.1 Service overview .....                               | 23 |
| 4.3.1.2 Service definition .....                             | 23 |
| 4.3.2 Interface service specifications for MAC sublayer..... | 24 |
| 4.3.2.1 MAC data service interface.....                      | 24 |
| 4.3.2.1.1 Overview of correlations between primitives.....   | 24 |
| 4.3.2.1.2 Specifications for service contents.....           | 24 |
| 4.3.2.1.2.1 MA-UNITDATA Request.....                         | 24 |
| 4.3.2.1.2.2 MA-UNITDATA Indication.....                      | 25 |
| 4.3.3 Link address (MAC address) architecture and SAP.....   | 26 |
| 4.3.4 MAC sublayer functions.....                            | 27 |
| 4.3.4.1 CS time DIFS.....                                    | 27 |
| 4.3.4.2 Random backoff time.....                             | 28 |
| 4.3.5 Access Control .....                                   | 29 |
| 4.3.6 Data transmission/reception control .....              | 29 |
| 4.4 Standard for Layer 7.....                                | 29 |
| 4.4.1 Overview .....   | 29 |
| 4.4.1.1 Configuration.....                                   | 30 |
| 4.4.1.2 Definitions (terms).....                             | 30 |
| 4.4.1.3 Data units used in communications.....               | 30 |
| 4.4.2 Overview of service contents .....                     | 30 |
| 4.4.3 Layer 7 service interface.....                         | 30 |
| 4.4.3.1 Overview.....  | 30 |
| 4.4.3.2 Overview of the correlation between primitives ..... | 30 |
| 4.4.3.3 Specifications for service contents.....             | 31 |
| 4.4.3.3.1 GET primitive.....                                 | 31 |

---

---

|   |    |
|---|----|
| 4.4.3.3.2 SET primitive .....   | 32 |
| 4.4.3.4 Parameters .....  | 32 |
| 4.4.3.5 Sequence .....  | 33 |
| 4.5 System Management .....   | 33 |
| Chapter 5: Measurement (Test) Method.....   | 34 |
| Chapter 6: Terms and Abbreviations .....  | 36 |
| 6.1 Terms .....   | 36 |
| 6.2 Abbreviations .....   | 37 |
| Appendix A [reference]: Definition of Application Data .....  | 42 |
| Appendix B [reference]: Additional Specification of Inter-application Communication (IP Packet Transparent Communication) ..... | 48 |
| Appendix C [reference]: Example of Application Requirements (Communication Area) .....  | 49 |

[Blank]

## Chapter 1: General Descriptions

### 1.1 Overview

This guideline describes the use of the radio communication interfaces between land mobile stations in the experiments on vehicle communications systems that use the 700 MHz-Band with reference to the ARIB STD-T71.

### 1.2 Scope of this guideline

Inter-vehicle communication is expected to be applied mainly to driver assistance systems because of its capability to enable low-latency communications between vehicles in any location including where there is no roadside equipment.

This system comprises a number of vehicle-mounted 700 MHz-Band radio equipment (hereafter “land mobile station” or “on-board equipment”), and each on-board equipment is supposed to perform broadcast communications for driver assistance with an unspecified number of on-board equipment at an interval specified by the application.

Number of on-board equipment transmit and receive signals to and from each other in order to mutually recognize and understand the positions, direction of travel, and drivers’ intentions of the other vehicles in the vicinity; thus, this system contributes to the reduction of vehicle-to-vehicle accidents at, for example, an intersection with blind corners.

This guideline specifies the radio communication interfaces for the system, as shown in Figure 1.2-1.

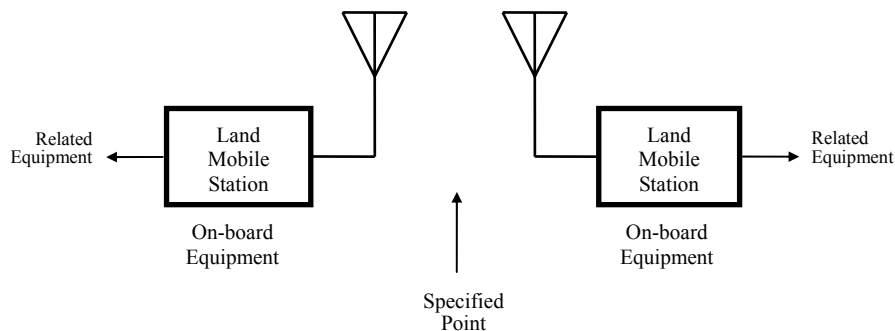

Fig.1.2-1: System Configuration

As only certain driver assistance applications are assumed to be developed, the form of communication is limited to broadcast communication with undesignated vehicles. The support for multiple applications, including peer-to-peer communication and inter-group communication with designated vehicles, and the form of such communications, shall be separately considered as tasks for system extension in the future.

### 1.3 Guideline Principles

The scope of this guideline is shown in Figure 1.3-1. The guideline is intended for a three-layer structure based on the Open Systems Interconnection (OSI) reference model; Layer 1, Layer 2, and Layer 7 are covered in this guideline. Since this system is required to support broadcast communications among an unspecified number of on-board equipment within a short time with low latency, the functions specified at Layer 3, Layer 4, Layer 5, and Layer 6 of the OSI reference model are specified at Layer 7.

In addition, the standard for Layer 7 and part of the standard for Layer 1 and Layer 2 have been referred to in order to support the intended experiments of this guideline. Such references have been indicated by “[reference]” (not mandatory) when specifically designing experimental mobile stations (on-board equipment).

Variables and information fields, which are indicated by “to be determined” or “[TBD]” in this guideline, will be determined through further consideration and verification in the future and those indicated by “Reserved” are to be used in the future extensions of definitions. However, some of these variables and information fields may contain specific values or identifiers, and it must be noted that their contents are subject to change in future revisions of this guideline.

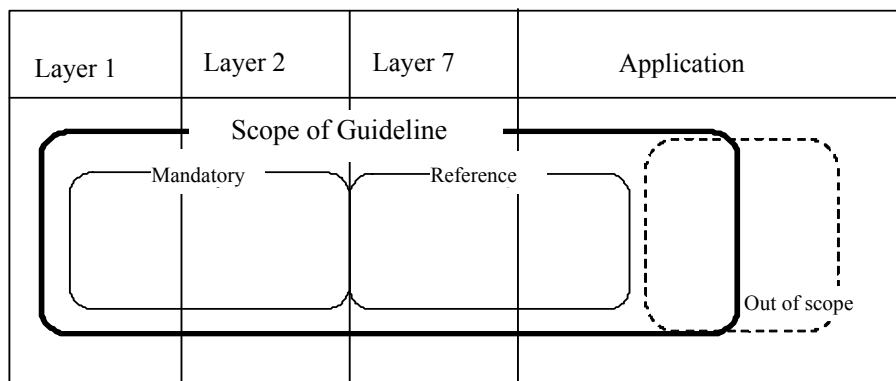

Fig. 1.3-1: Scope of this guideline

### 1.4 References

#### 1.4.1 Normative References

Unless otherwise specified, the terms used in this experimental guideline are in accordance with the definitions used in the Radio Act and ministerial ordinances. This guideline also complies with the standards listed below. Please refer to the following chapters for the details.

- [1] “Broadband Mobile Access System (CSMA) Standard,” ARIB STD-T71 Version 5.0, Association of Radio Industries and Businesses. (Japanese language only)

#### 1.4.2 Informative References

- [1] IEEE802.11-2007 IEEE Standard for Information technology—Telecommunications and information exchange between systems—Local and metropolitan area networks— Specific requirements Part 11: Wireless LAN Medium Access Control (MAC) and Physical Layer (PHY) Specifications

- [2] ITS FORUM RC-005 Version 1.0: “Experimental Guideline for Inter-Vehicle Communications System using 5.8 GHz-Band” ITS Info-communication Forum (May 18,2007) (Japanese language only)

## Chapter 2: System Overview

### 2.1 System Configuration

This system comprises a number of vehicle-mounted radio equipment (hereafter referred to as “on-board equipment (OBE)”).

#### 2.1.1 On-board Equipment (OBE)

The OBE performs land mobile radio communication between other OBEs. One unit of OBE comprises wireless devices, which is composed of an antenna, a transmitter and a receiver, and other optional equipment.

### 2.2 Interface Definition

The reference points for the interfaces relevant to the system are as shown in Figure 2.2-1.

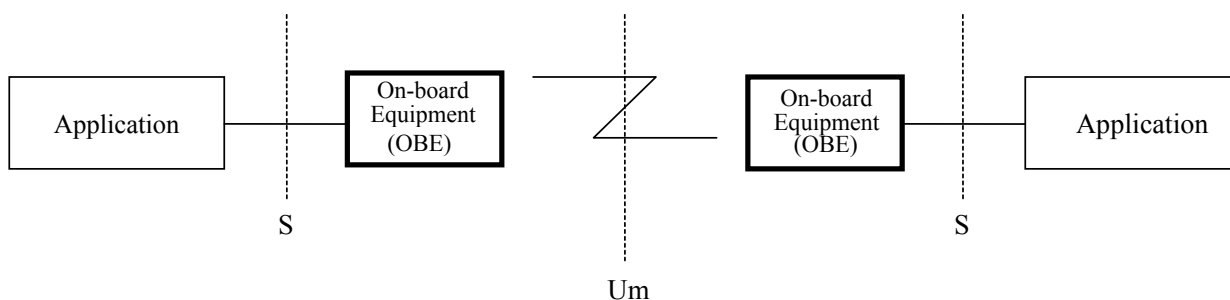

Point Um: Interface point between two OBEs; the point shall comply with this experimental guideline

Point S: Interface point between the OBE and the application: out of the scope of this experimental guideline

Fig. 2.2-1: Reference points for the interfaces

### 2.3 Basic Functions of the System

This system is used for communications between a number of OBEs and realizes functions such as

- (a) transmission and exchange of information that contributes to reducing the number of accidents and
- (b) transmission and exchange of information that relates to driver assistance.

#### 2.3.1 System Conditions

The conditions for this system are specified as follows.

##### 2.3.1.1 Basic Functions

- (1) This is a short-distance mobile communications system that connects multiple OBEs via high-speed radio links; the system is characterized by
  - (a) efficient frequency utilization achieved by adopting a small-zone configuration,
  - (b) capability of large capacity, high-speed, low-latency transmissions between moving vehicles, and

(c) broadcast communications with an unspecified number of OBEs.

It is assumed that the system is mainly meant for driver assistance applications.

The following assumptions are also made with respect to in-vehicle connectivity:

(d) connection to devices, e.g., GPS, that provide information about the same vehicle, and

(e) connection to in-vehicle display devices that provide information about other vehicles.

(2) The radio equipment functions provided by this system are specified as follows:

(a) this system comprises a number of OBEs, and the functions are realized by radio communications among them and

(b) communications shall be possible from the stationary state up to a relative speed between vehicles of approximately 140 km/h.

The amount of information may be restricted depending on the radio communication areas and speeds.

The target communication areas and the data transmission requirements for this system are described in Appendix C [reference] “Example of Application Requirements (communication area).”

### 2.3.2 Services provided by this system

#### 2.3.2.1 Service types

The functions provided by this system are assumed to be as follows:

(a) transmission and exchange of information that contributes to reducing the number of accidents, and

(b) transmission and exchange of information that relates to driver assistance.

An overview of these services is given in Appendix C [reference] “Example of Application Requirements (communication area),” and the information (data) definitions for driver assistance applications are given in Appendix A [reference] “Definition of Application Data.”

## 2.4 Access Control

### 2.4.1 Transmission Scheme

The radio communication access control used in this system is the Carrier Sense Multiple Access/Collision Avoidance (CSMA/CA) scheme as shown in Table 2.4-1.

Table 2.4-1: Specifications of the transmission scheme

| Items                      | Specifications                         |
|----------------------------|--|
| Operating frequency        | A single frequency in 700 MHz-Band     |
| Data frame length          | Any length from 0 to 1,500 (octets)    |
| Frequency selection        | Not required (fixed)                   |
| Scramble                   | Comply with ARIB STD-T71               |
| Error correction           | Convolution FEC R=1/2, 3/4             |
| Modulation                 | BPSK OFDM/QPSK OFDM/16QAM OFDM         |
| Transmission power control | To be dealt with at experimental phase |
| PHY header                 | Comply with ARIB STD-T71               |
| Media access control       | CSMA/CA                                |

### 2.4.2 Radio Link Control

The communication control procedure is the CSMA/CA scheme that is suitable for short-time broadcast communications among a number of OBEs. Each OBE uses a single, allocated transmission channel (frequency) to perform broadcast communications with a number of OBEs in the communication area.

## 2.5 Protocol

### 2.5.1 Protocol Stack

Figure 2.5-1 shows the protocol stack specified by this guideline. Each layer is specified with reference to the Open System Interconnection (OSI) reference model. This guideline has a three-layer structure comprising Layer 1 (Physical Medium Layer: L1), Layer 2 (Data Link Layer: L2), and Layer 7 (Application Layer: L7). Other stipulations, such as the service primitive between the application and Layer 7, are also included.

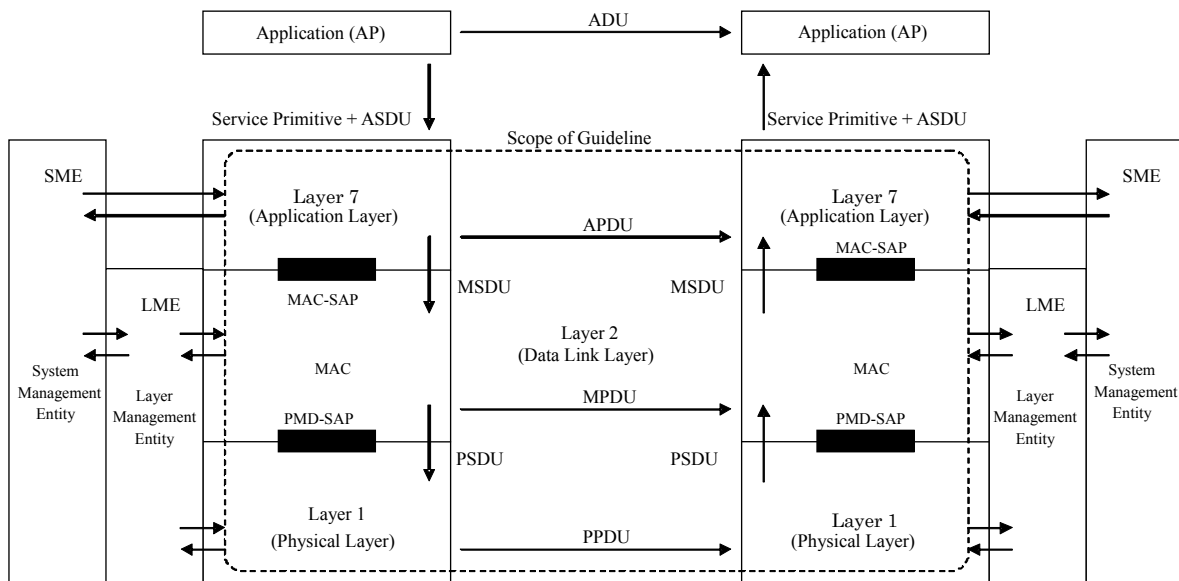

APDU: Application Protocol Data Unit

SAP: Service Access Point

PPDU: PLCP Protocol Data Unit (PLCP: Physical Layer Convergence Protocol)

Fig. 2.5-1: Protocol stack specified by this guideline

#### 2.5.1.1 Features of Layer 1

Layer 1 performs functions and operations related to the PHY (physical layer) of the ARIB STD-T71. Details are specified in Section 4.2, "Layer 1."

#### 2.5.1.2 Features of Layer 2

Layer 2 describes the CSMA/CA scheme as the MAC sublayer for use in experiments. The CSMA/CA scheme offers flexibility in changing key parameters such as the data length and transmission cycle; it also ensures low-latency, high-quality communication even in vehicle communications, where frequent connections/disconnections to the network will occur.

The radio channel communication management at the MAC sublayer supports frame control and broadcast communication. Details are specified in Section 4.3, "Layer 2."

### 2.5.1.3 Features of Layer 7

Layer 7 provides means of communication control to applications. Layer 7 both enables services to be provided to applications and transmits and receives the data (refer to Appendix A [reference] “Definition of Application Data”) via Layer 2. In addition, Layer 7 performs application management in conjunction with Layer 2. Details are specified in Section 4.4 “Layer 7.”

### 2.5.2 Numbering Plan (addressing)

The link address (MAC address) is used as a number to identify each on-board equipment. The link address generation scheme is not specified in this experimental guideline. This address is also used as the identification number of the Service Access Points (SAP) at Layer 1, Layer 2, and Layer 7 of the OBE.

### 2.6 Security Measures

Not specified in this experimental guideline.

## Chapter 3: Technical Conditions for Radio Equipment

### 3.1 Overview

This chapter specifies the technical conditions for radio equipment.

### 3.2 General Conditions

(1) Operating frequency band

The 700 MHz-Band shall be used as the operating frequency band.

(2) Radio communication scheme

Broadcast communication shall be the specified radio communication scheme (Note: refer to Appendix C [reference] “Example of Application Requirements (communication area)”).

(3) Communication content

Communication content shall be transmitted as digitized data signals.

(4) Usage environment condition

Shall be used in the specified range approved for the experimental radio station.

### 3.3 Transmitter

(1) Modulation scheme

The modulation scheme will be orthogonal frequency division multiplexing (OFDM). The number of carrier waves per 1 MHz of bandwidth shall be one (1) or more for OFDM.

(2) Transmit power level at the antenna input

The average power in the 1 MHz-Bandwidth shall be 10 mW or less.

(3) Tolerances for antenna power

The tolerances for antenna power (the maximum permissible deviations from the specified or rated antenna input power) are 20% (upper limit) and 80% (lower limit).

(4) Transmission data rate

The signal transmission data rate shall be selected with reference to the signal speed (data rate) specified in Section 4.2.4.2.

(5) Tolerances for frequency

Shall be within  $\pm 20 \times 10^{-6}$

(6) Equivalent isotropic radiated power

This is not specified for experimental radio stations; however, approximately 10 mW within a bandwidth of 1 MHz shall be considered as the standard power.

(7) Transmission burst length

Not specified for experimental radio stations.

(8) Adjacent channel leakage power

This is not specified for experimental radio stations. However, the leakage power shall not exceed the level that interferes with adjacent radio communication systems in the frequency band approved for the experimental radio station.

(As a reference: the average power at the antenna terminal radiated within a bandwidth of  $\pm 4.5$  MHz at frequencies 10 MHz and 20 MHz from the allocated frequency shall not exceed 0.25 mW and 8  $\mu$ W, respectively.)

(9) Strength of spurious or unwanted emissions

This is not specified for experimental radio stations. However, the emission strength shall not exceed the level that interferes with adjacent radio communication systems in the frequency band approved for the experimental radio station. The definitions and tolerances for the strength of spurious and unwanted emissions are currently under consideration as follows:

(a) Definitions

“Spurious emissions” refer to the emissions at one or more radio frequencies outside the necessary bandwidth, including harmonic emissions, subharmonic emissions, parasitic radiations, and intermodulation and excluding out-of-band emissions; it shall be possible to reduce the levels of such emissions without affecting information transmission.

“Out-of-band emissions” refer to the emissions at radio frequencies adjacent to the necessary bandwidth, which are generated during the modulation process for information transmission.

“Unwanted emissions” refer to spurious emissions and out-of-band emissions.

“Spurious band domain” refers to the frequency band where spurious emission is dominant outside the out-of-band domain.

“Out-of-band domain” refers to the frequency band where out-of-band emission is dominant outside the necessary bandwidth.

(b) Tolerances

The following are the tolerances for the strengths of spurious and unwanted emissions from the transmission equipment of the radio station, where radio equipment is tested by making components

communicate with each other:

- (i) Tolerance for spurious emission strength in out-of-band domain.

This is not specified for experimental radio stations.

- (ii) Tolerance for unwanted emission strength in spurious band domain.

This is not specified for experimental radio stations.

- (iii) Boundary frequencies of out-of-band domain and spurious band domain.

This is not specified for experimental radio stations. The recommended boundary frequencies are  $\pm 22.5$  MHz of the carrier wave. Measurements shall be taken during transmission, and the measurement durations shall be the transmission duration and non-transmission duration.

- (10) Permissible values for occupied bandwidth

The occupied bandwidth shall not exceed 9 MHz.

### 3.4 Receiver

The receiver sensitivity and carrier sense level are specified in Section 4.2 “Layer 2.”

- (1) Limit on secondary radiated emission, etc.

This is not specified for experimental radio stations. However, the following power levels are recommended as the limits on secondary radiated emissions, etc., to avoid the interference with other radio equipment: when measured with a dummy antenna that has the same electrical constants as the actual antenna, the power level at the antenna input shall be 4 nW or less at frequencies below 1 GHz and 20 nW or less at 1 GHz and above. In addition, the power level shall not exceed the level that interferes with adjacent radio communication systems on the frequency band approved for the experimental radio station.

- (2) Frequency variation of local oscillator

- (a) Definition

Frequency variation refers to the maximum fluctuation range of the oscillating frequency of the local oscillator.

- (b) Standard

This is not specified for experimental radio stations.

### 3.5 Controller

The following devices and functions, which comply with the corresponding requirements, shall be made available to the controller. In this experimental guideline, connections to telecommunication facilities are

not assumed.

### 3.5.1 Interference Rejection

Shall transmit or receive a frame (packet) attached with a 48-bit or longer identification number (link address: MAC address) that is unique to the transmission experiment station (transmitting radio equipment).

### 3.6 Antenna

#### (1) Antenna structure

This is not specified for experimental radio stations.

#### (2) Antenna gain

This is not specified for experimental radio stations. However, it is advisable that the antenna has a gain of 0 dBi and is non-directional in the horizontal plane.

#### (3) Polarization

##### (a) Standard

This is not specified for experimental radio stations. However, it is advisable that both the transmitting and receiving sides have the same polarization.

### 3.7 Clear channel assessment (CCA) method, technical conditions for carrier sense

- (1) When the carrier sense detects a radio wave emitted from a radio station other than the communicating counterpart, and if the reception level in the maximum-gain direction of the receiving antenna (standard antenna gain: 0 dBi) is equal to or greater than the CCA sensitivity specified in Section 4.2.5.7.5, the carrier sense shall prevent the emission of radio waves in the same frequency as that emitted from the aforementioned radio station.
- (2) The radio equipment shall start transmission only after the carrier sense has been performed.
- (3) The technical conditions for the carrier sense are specified in Section 4.3.4.1.

### 3.8 Miscellaneous

#### 3.8.1 Cabinet

- (1) The part of the cabinet containing high-frequency equipment, except the antenna system, and the modulation equipment shall not be easy to open.
- (2) The radio equipment to be used shall be housed in a single cabinet that is not easy to open. In addition to the previous clause (a), those devices that meet the following conditions need not be contained in a

single cabinet.

- (3) The devices that are part of the radio equipment need not be contained in a single cabinet:
  - (a) Power supply devices
  - (b) Antenna system
  - (c) Operating devices, display devices, and their equivalents.

### 3.8.2 Security measures

This is not specified for experimental radio stations.

### 3.8.3 Countermeasures against electromagnetic interference

Sufficient countermeasures shall be taken against mutual electromagnetic interference with other in-vehicle electronic devices.

## Chapter 4: Communication Control

### 4.1 Overview

In this chapter, the communication control of the radio communication interfaces for this radio communication system is specified. The interfaces are described in the following sections, according to the protocol stack described in Chapter 2.

#### 4.1.1 Overview of layers, layer management, and services between system managements

The ARIB STD-T71 will apply to layers, layer management, and services between system managements, which are not specified in this experimental guideline.

### 4.2 Standard for Layer 1

#### 4.2.1 Overview

In this section, the radio communication interfaces for this radio communication system are described and the structural conditions for Layer 1 including frame structure, channel structure, and signal structure are clarified.

Layer 1, which is specified by this guideline as shown in Figure 2.5-1 (“protocol stack”), is separately specified by dividing it into the physical medium dependent (PMD) layer that specifies the PLCP protocol data unit (PPDU; Aired Frame) between the antennas of radio equipment and the physical layer convergence protocol (PLCP) layer that converts the frame format between the MAC sublayer and the PMD sublayer.

In this section, additional items that are required to adapt the OFDM physical layer to the PHY entity of the OFDM system and its original experimental guideline standard are also specified.

During experiments, this OFDM system provides a selected payload-data communication function from among 3, 4.5, 6, 9, 12, and 18 Mbit/s. This system uses 52 subcarriers modulated with BPSK, QPSK, or 16QAM. This system also performs error correction coding (convolution coding) with an encoding ratio of 1/2 or 3/4.

#### 4.2.2 Features of Services

##### 4.2.2.1 Service access point

The service access point between Layer 1 and Layer 2 is set by the link address (MAC address) and is used for the transmission service.

##### 4.2.2.2 Services provided by Layer 1

###### 4.2.2.2.1 Transmission capacity

Layer 1 shall provide transmit functions that enable communication channels to be transmitted.

#### 4.2.2.2.2 Start/stop

Functions and procedures that enable signal transmission in communication channels to be started/stopped according to the request from the application (such as detecting the level of the received signal) shall be provided.

#### 4.2.2.2.3 Maintenance and status indication

This is not specified for experimental use.

### 4.2.3 Communication Frame

#### 4.2.3.1 Structure of communication frame

The communication frame is specified with reference to the ARIB STD-T71. The specifications in this experimental guideline are as follows:

The frame format is shown in Figure 4.2-1, and the structure of the MAC protocol data unit (MPDU) is shown in Figure 4.2-2. In addition to the standard MAC header, an experimental MAC header (30 octets) is added in this experimental guideline. Refer to the ARIB STD-T71 for the detailed structure of the PPDU.

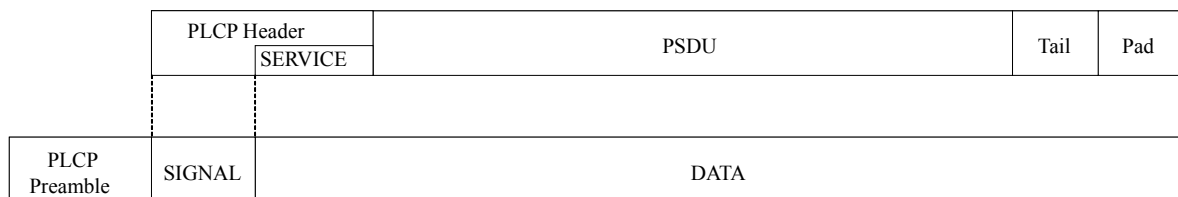

Fig. 4.2-1: Frame format

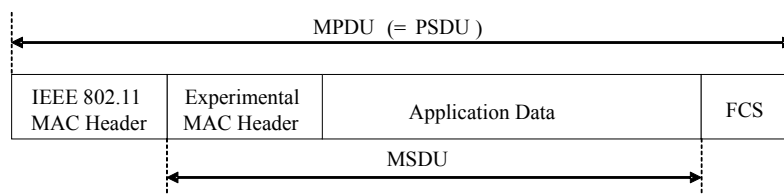

Fig. 4.2-2: MPDU frame format

#### 4.2.3.1.1 MAC header

Figure 4.2-3 shows the structure of the MAC header specified by this experimental guideline.

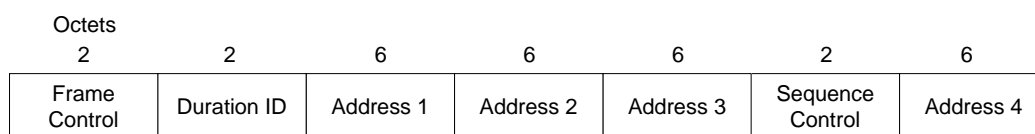

Fig. 4.2-3: Structure of MAC header

## 4.2.3.1.1.1 Frame control field

Figure 4.2-4 shows the subfields that comprise the frame control field, which is attached at the front of the MAC header.

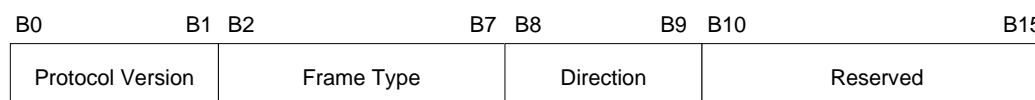

Fig. 4.2-4: Structure of frame control field

## \*Protocol Version (bit0, bit1):

According to this experimental guideline, this shall be “00.”

## \*Frame Type (bit2 through bit7):

According to this experimental guideline, bit2 is set to “0,” bit 3 to “1,” and bits4 through 7 are set to “0” as “Reserved.”

## \*Direction (bit8, bit9):

According to this experimental guideline, both bits are set to “1.”

## \*Reserved (bit10 through bit15):

All bits are set to “0.”

The MAC frame is verified by the MAC sublayer receiver processing at Layer 2, and those MAC frames that do not meet the above specification are rejected without being sent up to the higher layers.

## 4.2.3.1.1.2 Duration ID field

In this experimental guideline, bit15 and bit14 are set to “1,” and bits13 through 0 are set to “0” (“Reserved”).

## 4.2.3.1.1.3 Address 1 field

This field specifies the address of the destination terminal; details are given in Section 4.3.3.

## 4.2.3.1.1.4 Address 2 field

This field specifies the address of the originating terminal; details are given in Section 4.3.3.

#### 4.2.3.1.1.5 Sequence control field

According to this experimental guideline, this field is not divided into subfields and is incremented by one (1) for each MPDU transmission. After reaching 0xFFFF, this field is reset to 0x0000.

#### 4.2.3.1.1.6 Address 3 and Address 4 fields

These fields are normally disregarded in the MAC control header. Any non-affecting numerical values, such as application addresses, can be stored in the Address 3 and Address 4 fields. The details on these fields are specified in Section 4.3.3.

#### 4.2.3.1.2 Experimental MAC header

The length of the experimental MAC header is 30 octets. This experimental guideline does not provide the details of the frame format.

#### 4.2.3.1.3 FCS field

Error detection coding with 32-bit CRC is adopted. The calculation is performed entirely over the MAC header, experimental MAC header, and frame body. The transmitter sets the initial value of all the fields to “1,” and the following generator polynomial  $G(x)$  is used to divide the target range; the one’s complement of the residue with the high-order term at the head is transmitted.

$$G(x) = x^{32} + x^{26} + x^{23} + x^{22} + x^{16} + x^{12} + x^{11} + x^{10} + x^8 + x^7 + x^5 + x^4 + x^2 + x + 1$$

The receiver sets the initial values of all the fields to “1,” and  $G(x)$  is used to divide the entire range including the received FCS field; the receiver confirms that the residue corresponds to the following formula:

$$x^{31} + x^{30} + x^{26} + x^{25} + x^{24} + x^{18} + x^{15} + x^{14} + x^{12} + x^{11} + x^{10} + x^8 + x^6 + x^5 + x^4 + x^3 + x + 1$$

#### 4.2.3.1.4 Bit transmission sequence

The signal in each frame is transmitted with the least significant bit (LSB) at the head.

### 4.2.4 PLCP frame format

To be specified with reference to Section 5.3 of the ARIB STD-T71.

#### 4.2.4.1 Overview of the PPDU encoding process

To be specified with reference to Section 5.3.2.1 of the ARIB STD-T71.

#### 4.2.4.2 RATE-dependent parameters

This experimental guideline applies only the 10 MHz channel separation for BPSK, QPSK, and 16QAM transmission, listed in Table 5.3-1 of the ARIB STD-T71.

#### 4.2.4.3 Timing related parameters

To be specified with reference to Section 5.3.2.3 of the ARIB STD-T71. In order to address the large delay spread in the outdoor mobile environment, this experimental guideline applies only the 10 MHz separation for BPSK, QPSK, and 16QAM, where the clock cycle is doubled, as listed in Table 5.3-2 of the ARIB STD-T71.

#### 4.2.4.4 PLCP preamble (SYNC)

The communication frame is to be specified with reference to Section 5.3.3 of the ARIB STD-T71. In this experimental guideline, it is twice as long as the timing (e.g., in terms of the time factor) described in Section 5.3.3 of the ARIB STD-T71.

#### 4.2.4.5 Signal field (SIGNAL)

To be specified with reference to Section 5.3.4 of the ARIB STD-T71.

##### 4.2.4.5.1 Data rate (RATE)

This experimental guideline applies only the 10 MHz separation for BPSK, QPSK, and 16QAM, as listed in Table 5.3-3 of the ARIB STD-T71.

##### 4.2.4.5.2 PLCP length field (LENGTH)

To be specified with reference to Section 5.3.4.2 of the ARIB STD-T71.

##### 4.2.4.5.3 Parity (P), reserved (R), and signal tail (SIGNAL TAIL)

To be specified with reference to Section 5.3.4.3 of the ARIB STD-T71.

#### 4.2.4.6 DATA field

To be specified with reference to Section 5.3.5 of the ARIB STD-T71. In this experimental guideline, the maximum payload length shall be 1,500 octets or less.

##### 4.2.4.6.1 Service field (SERVICE)

To be specified with reference to Section 5.3.5.1 of the ARIB STD-T71.

#### 4.2.4.6.2 PPDU tail bit field (TAIL)

To be specified with reference to Section 5.3.5.2 of the ARIB STD-T71.

#### 4.2.4.6.3 Pad bits (PAD)

To be specified with reference to Section 5.3.5.3 of the ARIB STD-T71. In this guideline, it must be noted that this is a time parameter for the 10 MHz channel separation scheme.

#### 4.2.4.6.4 PLCP DATA scrambler and descrambler

To be specified with reference to Section 5.3.5.4 of the ARIB STD-T71.

#### 4.2.4.6.5 Convolutional encoder

To be specified with reference to Section 5.3.5.5 of the ARIB STD-T71.

#### 4.2.4.6.6 Data interleaving

To be specified with reference to Section 5.3.5.6 of the ARIB STD-T71.

#### 4.2.4.6.7 Subcarrier modulation mapping

To be specified with reference to Section 5.3.5.7 of the ARIB STD-T71. In this experimental guideline, it is only applied to BPSK, QPSK, or 16QAM.

#### 4.2.4.6.8 Pilot subcarriers

To be specified with reference to Section 5.3.5.8 of the ARIB STD-T71.

#### 4.2.4.6.9 OFDM modulation

To be specified with reference to Section 5.3.5.9 of the ARIB STD-T71.

#### 4.2.4.7 Clear channel assessment (CCA)

To be specified with reference to Section 5.3.6 of the ARIB STD-T71. This experimental guideline is specified as follows:

Layer 1 shall be capable of performing CCA and shall report the result to the MAC sublayer. The CCA mechanism shall detect the “channel busy” status according to the performance criteria specified in Section 4.2.5.7.5.

#### 4.2.4.8 PLCP data modulation and modulation rate change

To be specified with reference to Section 5.3.7 of the ARIB STD-T71. The specifications in this experimental guideline are as follows:

The SIGNAL field indicates the modulation scheme and the encoding ratio, which are used to transmit the MPDU.

The transmitter (receiver) is supposed to set the modulation (demodulation) scheme according to the RATE indicated in the SIGNAL field. The MPDU transmission speed is passed from the higher layers (application) and set in this layer. This experimental guideline does not provide the details concerning the exchange of the RATE (transmission speed information).

#### 4.2.5 Physical Medium Dependent (PMD) layer specifications

To be specified with reference to Section 5.3.8 of the ARIB STD-T71.

##### 4.2.5.1 PMD operating specifications (general)

To be specified with reference to Section 5.3.8 of the ARIB STD-T71. In this experimental guideline, this standard represents the general specifications for the physical medium dependent (PMD) sublayer for BPSK-OFDM, QPSK-OFDM, and 16QAM-OFDM. The main points are described in the following subsections.

##### 4.2.5.2 Outline description

To be specified with reference to Section 5.3.8.1 of the ARIB STD-T71. Only the 10 MHz channel separation listed in Table 5.3-9 of the ARIB STD-T71 shall be considered as the primary specification for OFDM PHY. Table 4.2-1 shows the key parameters in this experimental guideline.

Table 4.2-1: Key parameters for OFDM PHY

|                        |                                      |
|------------------------|--------------------------------------|
| Transmission data rate | 3, 4.5, 6, 9, 12, and 18 Mbit/s      |
| Modulation scheme      | BPSK-OFDM<br>QPSK-OFDM<br>16QAM-OFDM |
| Error correcting code  | K = 7 (64 states) Convolutional code |
| Coding rate            | 1/2, 3/4                             |
| Number of subcarriers  | 52                                   |
| OFDM symbol interval   | 8.0 $\mu$ s                          |
| Guard interval         | 1.6 $\mu$ s                          |
| Occupied bandwidth     | 8.3 MHz                              |

#### 4.2.5.3 Slot time

To be specified with reference to Section 5.3.8.6 of the ARIB STD-T71. According to this experimental guideline, the slot time is 13  $\mu$ s.

#### 4.2.5.4 Transmit and receive antenna port impedance

To be specified with reference to Section 5.3.8.7 of the ARIB STD-T71. In this experimental guideline, an impedance of 50  $\Omega$  is specified for the TX/RX antenna port, if the antenna is equipped with the terminal.

#### 4.2.5.5 Transmit and receive operating temperature range

This is not specified.

#### 4.2.5.6 PMD transmit specifications

To be specified with reference to Section 5.3.9 of the ARIB STD-T71.

##### 4.2.5.6.1 Symbol clock frequency tolerance

To be stipulated with reference to Section 5.3.9.5 of the ARIB STD-T71.

##### 4.2.5.6.2 Modulation accuracy

To be specified with reference to Section 5.3.9.6 of the ARIB STD-T71.

##### 4.2.5.6.3 Transmitter center frequency leakage

To be specified with reference to Section 5.3.9.6.1 of the ARIB STD-T71.

##### 4.2.5.6.4 Transmitter spectral flatness

To be specified with reference to Section 5.3.9.6.2 of the ARIB STD-T71.

##### 4.2.5.6.5 Transmitter modulation accuracy

To be specified with reference to Section 5.3.9.6.3 of the ARIB STD-T71. This experimental guideline does not cover 64QAM listed in Table 5.3-11 “Standard for allowed relative constellation error” of the ARIB STD-T71.

#### 4.2.5.7 PMD receive specifications

To be specified with reference to Section 5.3.10 of the ARIB STD-T71.

#### 4.2.5.7.1 Receiver minimum input level sensitivity

To be specified with reference to Section 5.3.10.1 of the ARIB STD-T71. According to this experimental guideline, the minimum sensitivity shall at least adhere to the standard listed in Table 5.3-12 “Receiver Performance Requirements” of the ARIB STD-T71, except the standard for the 10 MHz channel separation for 64QAM.

#### 4.2.5.7.2 Adjacent channel rejection [reference]

To be specified with reference to Section 5.3.10.2 of the ARIB STD-T71. Since only a single channel is considered in this experimental guideline, in a strict sense, this standard is out of scope. When performing experiments, it is advisable that the standard listed in Table 5.3-12 “Receiver Performance Requirements” (except the standard for 10 Hz channel separation for 64QAM) of the ARIB STD-T71 be adhered to as the minimum requirement in order to improve the resistance against interference from adjacent radio equipment.

#### 4.2.5.7.3 Non-adjacent channel rejection [reference]

To be specified with reference to Section 5.3.10.3 of the ARIB STD-T71. Since only a single channel is considered in this experimental guideline, in a strict sense, this standard is out of scope. When performing experiments, it is advisable that the standard listed in Table 5.3-12 “Receiver Performance Requirements” (except the standard for 10 MHz channel separation for 64QAM) of the ARIB STD-T71 be adhered to as the minimum requirement in order to improve the resistance against interference from adjacent radio equipment.

#### 4.2.5.7.4 Receive maximum input level

To be specified with reference to Section 5.3.10.4 of the ARIB STD-T71. The maximum input level of (-30) [TBD] dBm shall be achieved for all modulation schemes.

#### 4.2.5.7.5 CCA sensitivity

To be specified with reference to Section 5.3.10.5 of the ARIB STD-T71. This experimental guideline only applies the 10 MHz channel separation.

#### 4.2.6 PLCP transmit procedure

To be specified with reference to Section 5.3.11 of the ARIB STD-T71.

#### 4.2.7 PLCP receive procedure

To be specified with reference to Section 5.3.12 of the ARIB STD-T71.

#### 4.2.8 OFDM TXTTIME calculation

To be specified with reference to Section 5.4.3 of the ARIB STD-T71. This experimental guideline only applies the 10 MHz channel separation for BPSK, APSK, and 16QAM.

#### 4.2.9 OFDM PHY characteristics

To be specified with reference to Section 5.4.4 of the ARIB STD-T71. This experimental guideline only applies the 10 MHz channel separation for BPSK, APSK, and 16QAM listed in Table 5.4-2 “OFDM PHY Characteristics” of the ARIB STD-T71.

### 4.3 Standard for Layer 2

Layer 2 is the data link layer and specifies the medium access control (MAC) sublayer. While the logical link control (LLC) sublayer is not utilized, the MAC sublayer enables data transmission to Layer 7.

#### 4.3.1 MAC sublayer

##### 4.3.1.1 Service overview

The MAC sublayer performs communication control for the transport channel of Layer 1.

As the MAC sublayer standard, the CSMA/CA (Carrier Sense Multiple Access / Collision Avoidance) scheme is adopted for access control. For physical and virtual CS functions, the CS (Carrier Sense) mechanism is utilized to determine the medium status. The physical CS mechanism is provided by Layer 1, and the details are given in the specifications of Layer 1. For the time interval between frames, the same backoff as IEEE802.11-2007 is adopted, and the backoff control parameter CW (Contention Window) is set to 15.

The communication frame at the MAC sublayer is specified in Section 4.2.3.2. With reference to this communication frame, the procedures and the corresponding details are given in the following subsections.

##### 4.3.1.2 Service definition

Specify the access control for the transmission channel (Layer 1) for communications between the Layer 2 MAC sublayer entities of the OBE; provide the data transmission service to Layer 7.

The primary functions of the MAC sublayer are as follows:

- (1) Create MPDU
- (2) Transmit and receive MPDU

### (3) CSMA control

#### 4.3.2 Interface service specifications for MAC sublayer

##### 4.3.2.1 MAC data service interface

###### 4.3.2.1.1 Overview of correlations between primitives

The MAC sublayer provides the following primitives to Layer 7:

MA-UNITDATA Request

MA-UNITDATA Indication

The MA-UNITDATA Request is passed from Layer 7 to the MAC sublayer to request MSDU transmission. The MA-UNITDATA Indication is passed from the MAC sublayer to Layer 7 to indicate the arrival of the MSDU.

###### 4.3.2.1.2 Specifications for service contents

This subsection specifies in detail the primitives and parameters that are related to services. The parameters (except “link address”) are described abstractly to specify the information required for the receiving entity. However, the specific implementation method used to provide this information is not specified by this standard.

The link\_address (link address) identifies own station’s SAP and the SAPs of other stations of the MAC sublayer and Layer 7. The format of the link\_address parameter is specified separately.

The data parameter can be passed by several methods, such as passing the MSDU or passing the pointer.

Figure 4.3-1 shows the logical relation between primitives.

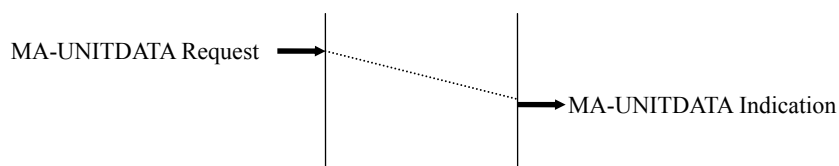

Fig. 4.3-1: Logical relation between primitives

###### 4.3.2.1.2.1 MA-UNITDATA Request

###### (1) Function

This primitive shall be the service request primitive that requests the transmission of MAC service data unit (MSDU).

###### (2) Parameters

This primitive has the following parameters.

MA-UNITDATA Request from the OBE:

(link\_address2, data, [link\_address4])

The link\_address2 parameter of the OBE is set with the destination link address. The data parameter is

set with the MSDU that is transferred by the MAC entity.

(3) Creation opportunity

This primitive is always created by the Layer 7 entity.

#### 4.3.2.1.2.2 MA-UNITDATA Indication

(1) Function

This primitive shall be the MSDU transfer primitive from the MAC entity to the Layer 7 entity.

(2) Parameters

This primitive has the following parameters:

MA-UNITDATA Indication: (link\_address1, data, [link\_address3])

The link\_address1 parameter is set using the link address for unicast, multicast, or broadcast communication. The data parameter is set using the MSDU received by the MAC entity.

(3) Creation opportunity

The MA-UNITDATA Indication primitive is passed from the MAC entity to the Layer 7 entity to indicate that the frame has arrived at the MAC entity.

### 4.3.3 Link address (MAC address) architecture and SAP

The link address (MAC address) consists of 48 bits. Figure 4.3-2 shows the structure of the link address (MAC address). “I/G” and “U/L” are the identification bits that indicate the classification of the link address (MAC address) architecture, which is described later.

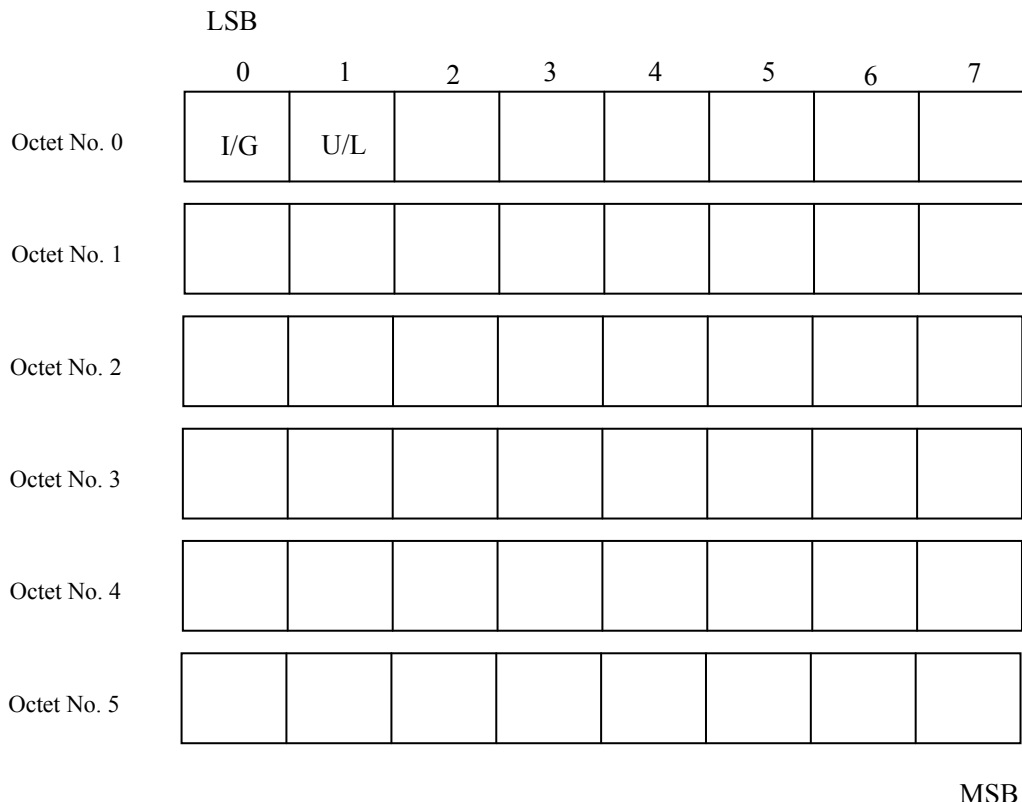

Fig. 4.3-2: Structure of link address (MAC address)

It is advisable to set and use the link address (MAC address) according to the following architecture:

(1) Universal address (“UL” = 0)

This is the link address that is under wide-area management. It is advisable to set the 24 higher-order bits in compliance with the Organizationally Unique Identifier (OUI), which is managed by IEEE.

The “I/G” identification bit specifies the following two types of link addresses:

(a) Individual address (“I/G” = 0)

This is the link address that is allocated to a single, designated OBE (terminal).

(b) Group address (“I/G” = 1)

This is the link address that is allocated to one or more components of the OBE (terminal). There are two types of link addresses:

## (i) Multicast group address

This is the group address associated with the logical relationship among components of the OBE (terminal); the address is specified at higher layers.

## (ii) Broadcast address (all bits set to “1”)

This is the predetermined, special multicast address that all components of the OBE (terminal) shall interpret. This address is generally used for broadcast communication to all components of the OBE (terminal).

## (2) Local address (“U/L” = 1)

This is the link address that is under local management. There are no restrictions on the address architecture configuration.

## 4.3.4 MAC sublayer functions

## 4.3.4.1 CS time DIFS

The time interval between frames (packets) is called the inter-frame space (IFS). The OBE (also called “STA” in the normative reference ARIB STD-T71) measures the IFS using the CS function. In this experimental guideline, this IFS is referred to as the distributed coordination function inter-frame space (DIFS). Figure 4.3-3 shows the relation between the DIFS and frame (packet).

The DIFS is defined by the timing intervals of the medium and has a fixed length at any data rate (transmission speed).

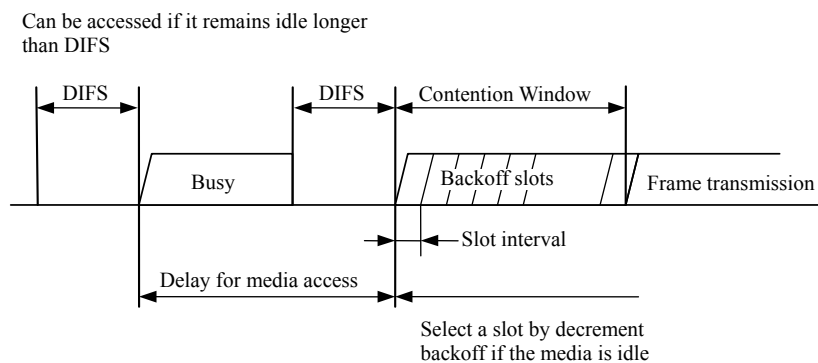

Fig. 4.3-3: Relation between DIFS and TX/RX frame (packet)

After receiving a packet (frame), the OBE uses the CS function to detect whether the medial is idle up to the slot boundary of TxDIFS, and the OBE is allowed to transmit when the backoff time has elapsed. When receiving a frame, if the received frame is decoded normally at Layer 1 and the data are passed to Layer 2, and further, if no error is detected in the frame by the frame check sequence (FCS), then the frame reception is said to have been successfully completed. TxDIFS is specified as follows:

$$\text{TxSIFS} = \text{SIFS} - \text{aRxTxTurnaroundTime}$$

$$\text{TxDIFS} = \text{TxSIFS} + 2 \times \text{aSlotTime}.$$

Table 4.3-1 shows the related time parameters.

Table 4.3-1: Time parameters related to MAC sublayer actions

| Characteristic Item | Specification in this experimental guideline |
|---------------------|--|
| aSlotTime           | 13 $\mu\text{s}$                             |
| aSIFSTime           | 32 $\mu\text{s}$                             |
| aCCATime            | < 8 $\mu\text{s}$                            |
| aRxTxTurnaroundTime | < 2 $\mu\text{s}$                            |
| aCWmin              | 15   |
| aCWmax              | 1023   |

#### 4.3.4.2 Random backoff time

The OBE, which starts MPDU transmission, uses CS to determine whether the medium is busy or idle. If the medium is busy, the OBE postpones the transmission by the DIFS time interval after the latest frame has been successfully received. If the medium has remained idle for the DIFS time and the backoff timer is “0,” the OBE generates a random backoff period by which the transmission is further postponed. If the backoff timer is not “0,” the random number is not required and the transmission is not postponed. Through this process, frame collisions among multiple components of the OBE are minimized during the contention period.

$$\text{Backoff Time} = \text{Random} () \times \text{aSlotTime}$$

where Random() is an integer selected from pseudorandom numbers that are uniformly distributed between 0 and the contention window (CW), and the CW is an integer between aCWmin and aCWmax specified by PHY.

Note that the random numbers for the OBE shall be statistically independent. In this experimental guideline, CW = 15 is fixed.

#### 4.3.5 Access Control

CSMA control (without retransmission control) is adopted as the access control for the MAC sublayer.

The procedure is as follows:

- (1) When transmitting the MPDU, generate a random number (integer only) in the range from 0 up to the specified CW and determine the backoff time that is obtained as the product of the time interval and the slot time.
- (2) Using the CS, wait until the channel remains idle (the received power level during the CS period is less than the carrier sense sensitivity) for the DIFS time.
- (3) If the channel still remains idle after Step (2), then subtract each individual slot time from the backoff time determined in Step (1) and transmit the MPDU as soon as the deducted backoff time equals 0.
- (4) If the channel becomes busy (the received power level during the CS period is equal to or greater than the CS sensitivity) during Step (2) or (3), wait until the channel becomes idle again. As soon as the channel becomes idle, perform Steps (2) and (3) on the basis of the backoff time deducted in Step (3).

#### 4.3.6 Data transmission/reception control

##### (1) Data transmission procedure

The data transmission procedure is the same for unicast, multicast, and broadcast communications. Carry out the access control procedure as described in the above section, and if the transmission rights are obtained, transfer PPDU to Layer 1. If a new MPDU arrives from the higher layers before completing PPDU transmission to Layer 1, then discard the previous PDU in the MAC sublayer.

##### (2) Data reception procedure

When a PPDU arrives from Layer 1, issue the MA-UNITDATA.Indication (DL-UN.indication) to the higher layers.

#### 4.4 Standard for Layer 7

##### 4.4.1 Overview

Layer 7 enables communication with applications. Application designers are supposed to develop applications using the means of communication provided by Layer 7.

The tasks specified for the application protocol data unit (APDU) are performed by the activation from the service primitive (SP).

The following content is covered within the scope of this experimental guideline:

Services that perform data transfer

Transmission time management, time synchronization, and consecutive transmission are out of the scope of this experimental guideline. These features are to be implemented by applications.

#### 4.4.1.1 Configuration

Services are provided to users by SPs, which provide the basic data transmission services. In this experimental guideline, SPs comprise peer-to-peer service primitives (see Note).

Note: A peer-to-peer service primitive is responsible for information transfer between two service users, and it is an abstract representation for realizing this transfer. The role is to perform APDU transfer.

#### 4.4.1.2 Definitions (terms)

##### (1) Application

A user that uses the services provided by the communication protocol stack.

##### (2) Element

An application element that is a set containing data and functions and is an abstract representation of the resources required for data processing and data communication. This application element is created by an application and addressed by an element identifier (EID).

##### (3) Element Identifier (EID)

An identifier that is used to uniquely identify the elements inside the OBE.

#### 4.4.1.3 Data units used in communications

##### (1) Application Data Unit (ASDU)

A data unit that is defined within an application. This data unit is transferred between two application entities.

##### (2) Application Protocol Data Unit (APDU)

A data unit that is used for data exchange among application service elements within the same group.

#### 4.4.2 Overview of service contents

Layer 7 provides services to other elements (transfer service users) as follows:

##### (1) GET

##### (2) SET

#### 4.4.3 Layer 7 service interface

##### 4.4.3.1 Overview

The communication between Layer 7 and AP is performed via the primitives provided by Layer 7.

##### 4.4.3.2 Overview of the correlation between primitives

In this experimental guideline, the primitive types listed below are specified. Figure 4.4-1 shows the

relation between primitive types and applications.

(1) Request

The request primitive type is used when the application (AP) requests a service from Layer 7.

(2) Indication

The indication primitive type is used when Layer 7 notifies the application (AP) of the service from the other application (AP).

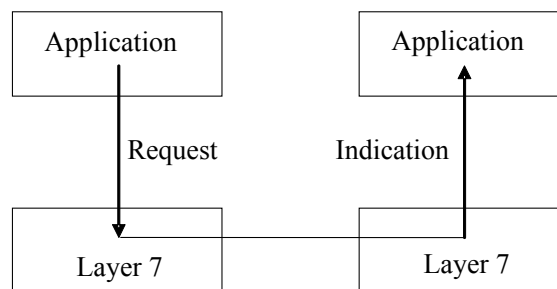

Fig. 4.4-1: Relation between Layer 7 and applications in terms of primitive types

#### 4.4.3.3 Specifications for service contents

##### 4.4.3.3.1 GET primitive

(1) Function

The GET primitive is used when receiving information retrieval from other applications. This service is not considered in this experimental guideline.

(2) Format

Details are not provided in this experimental guideline.

4.4.3.3.2 SET primitive

(1) Function

The SET primitive is used when changing information in other applications. This service can be used in either verification type or non-verification type, and the verification type requires a response. The non-verification type is considered in this experimental guideline.

(2) Format

Use the following formats:

Set Request (.request) (EID, Element)

Set Indication (.indication) (EID, Element)

4.4.3.4 Parameters

The following parameters are used for the Layer 7 standard primitives. Bit 7 is the MSB unless otherwise specified. In the bit transmission sequence at Layer 7, the item that has a higher-order bit (MSB) at the head is transmitted first.

(1) Element Identifier (EID)

This indicates the identifier of an element. Figure 4.4-2 shows the structure of the EID. In this experimental guideline, EID is defined as “Reserved” (all bits set to “0”).

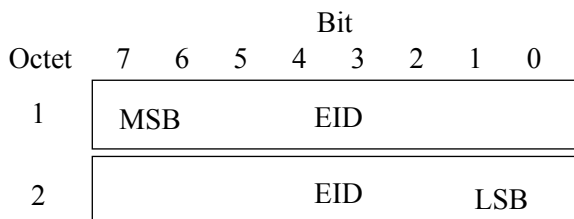

Fig. 4.4-2: Structure of EID

## 4.4.3.5 Sequence

Figure 4.4-3 shows an example of a communication sequence.

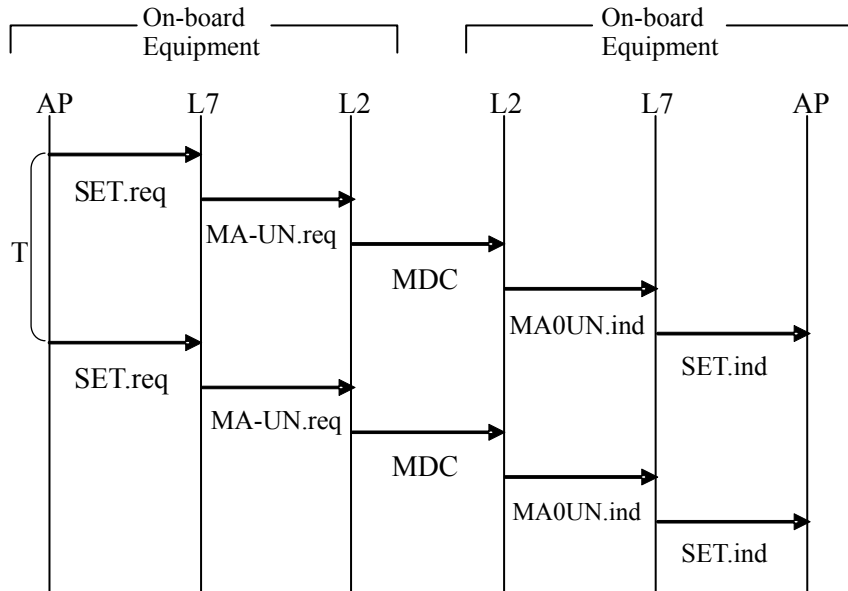

Fig. 4.4-3: Example of a communication sequence

## 4.5 System Management

System management determines the interfaces and procedures between individual layers and between each layer and the system (application). Refer to the ARIB STD-T71, as they are not specified by this standard in this experimental guideline.

## Chapter 5: Measurement (Test) Method

It is recommended that measurements should be performed with reference to the measurement method specified in the ordinance (will be specified in the separate table 1 of “Ordinance concerning Technical Regulations Conformity Certification etc. of Specified Radio Equipment,” issued by The Ministry of Internal Affairs and Communications ) or other measurement methods equivalent to or better than that method.

[Blank]

## Chapter 6: Terms and Abbreviations

### 6.1 Terms

The terms and abbreviations used in this guideline are defined as follows:

#### Mobile Station (OBE)

Synonymous with on-board equipment or land mobile station.

#### ASV (Advanced Safety Vehicle)

The Advanced Safety Vehicle development project, which is driven by The Ministry of Land, Infrastructure and Transport, in which all the vehicle and motorcycle manufacturers participate voluntarily.

#### Octet

An element comprising eight (8) adjacent binary bit strings.

#### Service

A function that is provided to the adjacent higher layer.

#### Service Primitive (SP)

A single independent process that is converged to realize the mutual interaction between one service user and the service provider.

#### Service User

An application service element or a user element that avails of services offered by the service provider.

#### CSMA/CA (Carrier Sense Multiple Access / Collision Avoidance)

A communication scheme that can be adopted to verify the channel utilization status before starting communication. If the channel is not in use, the transmission occurs immediately. If the channel is in use, the data is transmitted after the channel has changes to unused status, while avoiding collisions using the backoff algorithm.

#### Element Identifier

An element name used at Layer 7. Each device has a unique element name. An identification name and an element identification name are used under the concepts that differ from each other.

#### Data Link

An interconnected communication channel for information exchange between two or more terminal devices.

#### Medium Access Control (MAC)

A data processing function, which is part of Layer 2, that supports the medium access control below the LLC sublayer. The control procedure of this communication entity regulates the frame control of data format and the physical transmission channel of the underlying layer (Layer 1).

**Protocol Data Unit (PDU)**

A data unit that is exchanged between protocols of the same order.

**MAC Service Data Unit (MADU)**

A data unit that the MAC sublayer exchanges with the LLC sublayer of Layer 2.

**MAC Control Field**

A frame portion that stores the control information field, which is required for the MAC sublayer of Layer 2 to perform appropriate control.

**MAC Protocol Data Unit (MPDU)**

A data unit that is exchanged between the MAC sublayers of Layer 2.

**Land Mobile Station**

Synonymous with on-board equipment or mobile station.

**Link Address**

The initial address of the service access point of the LPDU; it can be used to differentiate between the SAP that is set to receive the PDU and the SAP that transmits the PDU. Identical to the MAC address architecture specified by the IEEE802 committee.

**Layer 1**

A component in a conceptual hierarchy; signal transmission at a physical medium is performed in Layer 1. Also called the “physical layer,” this layer provides Layer 2 with interfaces.

**Layer 2**

A component in a conceptual hierarchy; control and management of the data link are performed in Layer 2. Also called the “data link layer,” this layer provides Layer 7 with interfaces.

**Layer 7**

A versatile element in which several processing functions can be carried out for various applications. This layer provides applications with interfaces.

**6.2 Abbreviations****[A]**

- ADU : Application Data Unit  
AP : Application (also means “Access Point” in ARIB STD-T71)  
APDU : Application Protocol Data Unit  
ARIB : Association of Radio Industries and Businesses  
ASV : Advanced Safety Vehicle

**[B]**

BER : Bit Error Rate

BPSK : Binary Phase Shift Keying

[C]

CCA : Clear Channel Assessment

CRC : Cyclic Redundancy Check

CS : Carrier Sense

CSMA : Carrier Sense Multiple Access

CW : Contention Window

[D]

DIFS : Distributed (coordination function) Inter-frame Space

[E]

EIRP : Effective Isotropically Radiated Power

[F]

FC : Frame Control

FCS : Frame Check Sequence

FEC : Forward Error Correction

[G]

GPS : Global Positioning System

[H]

[I]

IEEE : Institute of Electrical and Electronics Engineers

IFS : Inter-Frame Space

IP : Internet Protocol

[J]

[K]

## [L]

L1 : Physical Medium Layer  
L2 : Data Link Layer  
L7 : Application Layer  
LID : Link Identifier  
LLC : Logical Link Control  
LME : Layer Management Entity  
LSB : Least Significant Bit

## [M]

MAC : Medium Access Control  
MPDU : MAC Protocol Data Unit  
MSB : Most Significant Bit  
MSDU : MAC Service Data Unit

## [N]

NW : Network

## [O]

OBE : On-Board Equipment  
OFDM : Orthogonal Frequency Division Multiplexing  
OSI : Open System Interconnection

## [P]

PDU : Protocol Data Unit  
PHY : Physical Layer  
PHY-SAP : Physical Layer Service Access Point  
PLCP : Physical Layer Convergence Protocol  
PMD : Physical Medium Dependent  
PN : Pseudo Noise (PN code sequence)  
PPDU : PLCP Protocol Data Unit  
ppm : Part Per Million  
PSDU : PLCP SDU

[Q]

QAM : Quadrature Amplitude Modulation

QPSK : Quadrature Phase Shift Keying

[R]

RX : Receive or Receiver

[S]

SAP : Service Access Point

SDU : Service Data Unit

SME : System Management Entity

[T]

TU : Time Unit

TX : Transmit or Transmitter

[U]

[V]

[W]

[X]

[Y]

[Z]

[Blank]

## Appendix A [reference]: Definition of Application Data

### A.1 Structure of data transmitted by applications

The structure of data transmitted by applications shall be based on the data structure considered by the Advance Safety Vehicle-4 (ASV-4) project. While a data structure with reserved fields was considered in the ASV-4 project, a data structure without reserved fields is defined here. The data structure comprises 20 fields, and their names and sizes are given below. The size of the data structure adds up to 399 bits (approx. 50 octets). The details of the data structure are listed in Appendix Table A.1-1.

Appendix Table A.1-1: Data Structure

| Item No. | Field Name  | Size (bit) |
|----------|---|------------|
| 1        | Field format version                                    | 8          |
| 2        | Identification number of source vehicle                 | 16         |
| 3        | Identification number of destination vehicle            | 16         |
| 4        | Type of source vehicle                                  | 4          |
| 5        | Geodetic system   | 2          |
| 6        | Horizontal direction error                              | 8          |
| 7        | Vertical direction error                                | 8          |
| 8        | Position of the source vehicle                          | 70         |
| 9        | Speed   | 8          |
| 10       | Traveling direction                                     | 9          |
| 11       | Vehicle gearbox shift position                          | 3          |
| 12       | Brake-lamp status                                       | 2          |
| 13       | Turn indicator SW status                                | 2          |
| 14       | Hazard indicator SW status                              | 2          |
| 15       | Emergency running status of emergency vehicle           | 1          |
| 16       | Departure signal of commercial vehicle                  | 1          |
| 17       | Arrival signal of commercial vehicle                    | 1          |
| 18       | Position of nearest intersection in traveling direction | 70         |
| 19       | Application message expression number                   | 8          |
| 20       | Free field  | 160        |

The fields from 1 to 20 are defined as follows:

## (1) Field format version

Indicates the version number of the field format. The version number defined in this specification is 0x01.

The link address refers to the address that is used for communication between different components of the OBE and comprises a combination of identification numbers of vehicle at origin and identification numbers of vehicle at destination.

## (2) Identification numbers of source vehicle (unsigned integer)

## (3) Identification numbers of destination vehicle (unsigned integer)

## (4) Type of source vehicle (4-bit bit string)

In order to identify the type of the source (e.g., vehicle or pedestrian) sending out the data, this field specifies the type that corresponds to the source of the message on the basis of the following definitions.

|   |        |
|---|--------|
| * Large automobiles including trucks and buses under government ordinance | : 0001 |
| * Trucks classified as ordinary vehicles                                  | : 0010 |
| * Special automobiles   | : 0011 |
| * Ordinary vehicles except trucks classified as ordinary vehicles         | : 0100 |
| * Two-wheeled motor vehicles  | : 0101 |
| * Motor bicycles with engine displacement of 125 cc or less               | : 0110 |
| * Bicycles  | : 1001 |
| * Lightweight vehicles except bicycles                                    | : 1010 |
| * Pedestrians   | : 1000 |
| * Others  | : 1111 |

## (5) Geodetic system (2-bit string)

Specifies the geodetic system (ITRF: 00, WGS-84: 01, Tokyo Datum: 10) used for latitude/longitude to indicate the position.

## (6) Horizontal direction error (unsigned integer, 8 bits)

Set the presumed position error in the horizontal direction. Set 0xFF if the presumed error is 256 m or more.

## (7) Vertical direction error (unsigned integer, 8 bits)

Set the presumed position error in the vertical direction. Set 0xFF if the presumed error is 256 m or more.

## (8) Position of the originator (70 bits)

## (a) Degrees of latitude (integer, 9 bits)

Indicate the “degrees” of the latitude/longitude of the position. Latitudes and longitudes in the northern and eastern hemisphere, respectively, correspond to “+”; latitudes and longitudes in the southern and western hemisphere, respectively, correspond to minus “-.”

- (b) Minutes of latitude (unsigned integer, 6 bits)

Indicate the “minutes” of the latitude/longitude of the position.

- (c) Seconds of latitude (unsigned integer, 13 bits)

A value obtained by multiplying the “seconds” of the latitude/longitude by 100. Comment: set a hundredfold value of the “seconds” of the latitude/longitude so as to transmit two significant digits after the decimal point using a smaller number of bits.

- (d) Degrees of longitude (integer, 9 bits)

Indicate the “degrees” of the latitude/longitude of the position. Signs are plus “+” for north latitude and east longitude and minus “-“ for south latitude and west longitude.

- (e) Minutes of longitude (integer 6 bits)

Indicate the “minutes” of the latitude/longitude.

- (f) Seconds of longitude (unsigned integer, 13 bits)

A value obtained by multiplying the “seconds” of the latitude/longitude by 100. Set a hundredfold value of the “seconds” of latitude/longitude so as to transmit the two significant digits after decimal point using a smaller number of bits.

- (g) Height (integer, 14 bits)

Set the height (m) from the origin of coordinate system. The signs “+” and “-” indicate that the position is higher and lower than the origin, respectively.

- (9) Speed (unsigned integer, 8 bits)

Set the speed (km/h) of own vehicle at the time of data transmission.

- (10) Traveling direction (unsigned integer, 9 bits)

These bits represent the traveling direction (in angular units) of own vehicles at the time of data transmission. With north defined as 0°, set an angle between 0° and 359° (clockwise).

The data, which most vehicles can automatically obtain and use to predict the driver’s intentions, contain information about vehicle equipment defined as follows (statuses of brake lamp, turn indicator, hazard indicator, and gearbox shift position):

- (11) Gearbox shift position of the vehicle (3-bit string)

Set the following shift positions of the vehicle:

|           |       |
|-----------|-------|
| * Parking | : 000 |
| * Drive   | : 001 |
| * Reverse | : 010 |

- 
- \* Other : 100
  - \* Shifter not equipped (e.g., pedestrian) : 111
- (12) Brake lamp status (2-bit string)
- Set the brake lamp status as follows:
- \* Brake lamp OFF : 00
  - \* Brake lamp ON : 01
  - \* Brake not equipped (e.g., pedestrian) : 11
- (13) Turn indicator SW status (2-bit string)
- Set the turn indicator SW status as follows:
- \* Turn indicator OFF : 00
  - \* Right-turn indicator ON : 01
  - \* Left-turn indicator ON : 10
  - \* Turn indicator absent (e.g., pedestrian) : 11
- (14) Hazard indicator SW status (2-bit string)
- Set the hazard indicator SW status as follows:
- \* Hazard indicator OFF : 00
  - \* Hazard indicator ON : 01
  - \* Hazard indicator not equipped (e.g., pedestrian) : 11

The emergency running status of emergency vehicles, which are classified as special purpose vehicles, and the information about fixed-route buses, such as arrival and departure information, are defined as follows. These definitions do not specify the method to indicate whether the own vehicle is a special-purpose vehicle.

- (15) Emergency running status of emergency vehicle (1-bit boolean)

Set the running status as follows:

- \* Normal running status : 0
- \* Emergency running status : 1

Only emergency vehicles are allowed to set this element to “emergency running status.” Other vehicles shall set it to 0.

- (16) Departure signal of commercial vehicle (1-bit boolean)

Set the following departure signal of commercial vehicle:

- \* Normal status : 0
- \* Start of departure : 1

Only fixed-route buses are allowed to set this field to “start of departure.” Other vehicles shall set it

to 0. The “start of departure” set here only refers to the departure of a fixed-route bus from a bus stop and does not indicate stopping or starting when the bus is running on the road.

(17) Arrival signal of commercial vehicle (1-bit boolean)

Set the following arrival signal:

\* Normal status : 0

\* Start of arrival : 1

Only fixed-route buses are allowed to set this field to “start of arrival.” Other vehicles shall set it to 0. The “start of arrival” set here only refers to the arrival of a fixed-route bus to a bus stop and does not indicate stopping or starting when the bus is running on the road.

It is difficult to determine if the own vehicle and the other vehicle are traveling toward the same intersection when only the vehicle positions are transmitted. This task may become relatively easy when the position information about the intersections toward which the vehicles are traveling is also transmitted. Therefore, the position data are defined to indicate the nearest intersection in the traveling direction. While a navigation system is required to transmit this data, it is assumed that most of the vehicles, which are equipped with inter-vehicle communication based driving support systems, are also equipped with navigation systems.

(18) Position of the nearest intersection in the traveling direction (70 bits)

Indicate the position (latitude, longitude, and height) of the nearest intersection in the traveling direction as a reference point to help vehicles determine each other’s relative positions and traveling directions.

(19) Application message expression number (8-bit string)

Since the data convey messages, for maximizing data efficiency while simultaneously minimizing cumbersome data inputs, the numbers of stylized messages—but not the character strings of free sentences—are defined as follows. Specify a desired message number.

(a) Mutual concessions

\* Please go ahead : 0x01

\* Thank you : 0x02

\* Please let me pull into traffic : 0x03

\* Please let me go first : 0x04

\* I will go first : 0x05

\* Sorry, I didn’t notice it : 0x06

\* Please cross the road : 0x07

(b) Pathway notices

\* Pulling into traffic : 0x11

---

|                            |        |
|----------------------------|--------|
| * Passing through          | : 0x12 |
| * Leaving traffic          | : 0x13 |
| * Changing lanes           | : 0x14 |
| * Stopping                 | : 0x15 |
| * Starting                 | : 0x16 |
| * Pulling into parking lot | : 0x17 |
| * Pulling into ETC lane    | : 0x18 |

## (c) Greetings

|           |        |
|-----------|--------|
| * Hello   | : 0x21 |
| * Goodbye | : 0x22 |

## (d) Information

|  |        |
|--|--------|
| * Slowing down due to traffic jam (in my traveling direction)        | : 0x31 |
| * Slowing down due to accident (in my traveling direction)           | : 0x32 |
| * Lights (of your vehicle) are turned on                             | : 0x33 |
| * Lights (of your vehicle) are glaring                               | : 0x34 |
| * Road surface is slippery (in my traveling direction)               | : 0x35 |
| * Road surface is slippery (in your traveling direction)             | : 0x36 |
| * Fog is rising (in my traveling direction)                          | : 0x37 |
| * Fog is rising (in your traveling direction)                        | : 0x38 |
| * It is raining (in my traveling direction)                          | : 0x39 |
| * It is raining (in your traveling direction)                        | : 0x3A |
| * Strong crosswind is blowing (in my traveling direction)            | : 0x3B |
| * Strong crosswind is blowing (in your traveling direction)          | : 0x3C |
| * Road is backed up (in my traveling direction)                      | : 0x3D |
| * Road is backed up (in your traveling direction)                    | : 0x3E |
| * Please pay attention (to my traveling direction)                   | : 0x3F |
| * Right-turning vehicle will move past (in your traveling direction) | : 0x40 |

This element aims to convey the defined content to drivers. As long as the aim is achieved, the character strings defined here may not necessarily be transmitted exactly as shown. In addition, the method of transmission is not specified.

## (20) Free field (160-bit string)

This is a data field that applications can use without any restriction, and the contents are not specified.

## Appendix B [reference]: Additional Specification of Inter-application Communication (IP Packet Transparent Communication)

While this experimental guideline specifies the communication protocol stack for inter-application communication via Layer 7, communications are also possible via other communication media (such as IEEE802.3u) in a bridged structure. Appendix Figure B.1-1 shows an example of IP packet transparent communication via the IEEE802.3u network (by bridging the network) in accordance with this experimental guideline. In this example, it is also possible to embed an encapsulated IP packet in the payload of the packet (data frame) and include the final communication transmission/reception (application) addresses in the Address3 and Address4 fields for use in inter-bridge communication.

Note: As this extended function does not use Layer 7 described in Section 4.4 (i.e., bypasses Layer 7), a conversion interface is required between the MAC sublayer and the IEEE802.3u layer; however, this experimental guideline does not specify the details of the conversion interface.

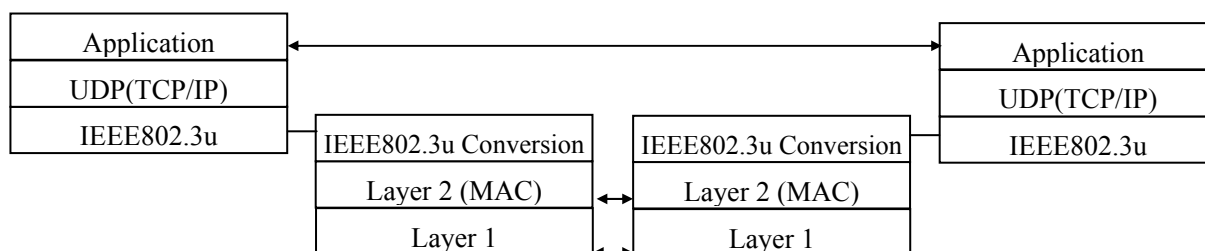

Appendix Fig. B.1-1: Example of Additional Specification of Inter-application Communication (IP Packet Transparent Communication)

## Appendix C [reference]: Example of Application Requirements (Communication Area)

### C.1 Application requirements and communication areas

In this appendix, the points that have been considered by the ASV-4 project are discussed in the context of the application (driver assistance system).

#### C.1.1 Basic ideas for consideration in ASV-4

##### (1) System concept for inter-vehicle communication type driver assistance

Basic concepts have been defined for the ASV (ASV-4) project to advance the development of communication-type driver assistance systems. When utilizing the communication-type driver assistance system, the requirements are given by the ideas listed in the concept specifications. The project is progressing and involves taking feasible elemental technologies into consideration and simplifying them to obtain more realistic system specifications before finalizing the system definition.

##### (2) System definition for inter-vehicle communication type driver assistance

On the basis of the specified system concepts mentioned above, further considerations are being given to the prerequisites, elemental technologies, and technological requirements in order to realize the operating conditions (such as communication range, communication distance, the number of communication targets) for driving support systems based on inter-vehicle communication.

Five types of traffic accidents are considered in the context of exchanging information (inter-vehicle communication) using the system: left-turn collision, right-turn collision, crossing collision, rear-end crash on the highway, and special events for emergency vehicles.

In this system, driver assistance is provided only to non-priority vehicles (NPV); however, if the NPV cannot determine the relative priority for vehicles in the vicinity, or if both vehicles have equal priority, then both vehicles are provided with the NPV driver assistance, subject to the requirement that both drivers should drive while simultaneously confirming mutual safety.

##### (3) Model cases for inter-vehicle communications system

The parts of the ASV-4 concept specifications and the system definitions relevant to communication areas are presented in this appendix. As for the concept specifications and the system definitions, the application images and the possible positions of antenna installation that have been assumed thus far are presented, and some of the ideas for communication area are modified on the basis of the results of the ongoing considerations of ASV-4. However, these considerations do not necessarily aim to specify the standard or target values when the application itself is realized.

With reference to the above considerations, the action scenarios for each type of accident and the required communication areas for these scenarios are derived in the context of the ASV-4 concept. However, in the ASV-4 concept, these scenarios and communication areas are regarded as the conditions for an ideal inter-vehicle communications system and are not regarded as the mandatory conditions. Here, the considerations are given in terms of how close the developed system can be to the ideal system when the media under consideration are used.

## C.2 Conditions for calculating communication areas

For a given action scenario in individual accident prevention-assistance scenes, the parameters used to calculate communication areas are listed below.

< Conditions to calculate communication areas >

- (1) The sum (s) of the information provision/response time, system delay time, and system processing time:  $3.7 + 0.3 + 0.1 = 4.1$  s.
- (2) Upper speed limit for the priority vehicle: 70 km/h
- (3) Antenna installation position

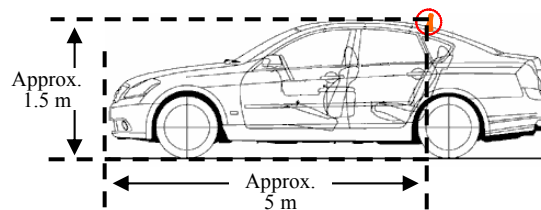

Appendix Fig. C.2-1: Passenger car (sedan): 5 m behind the front of the vehicle, on the rear side of the roof

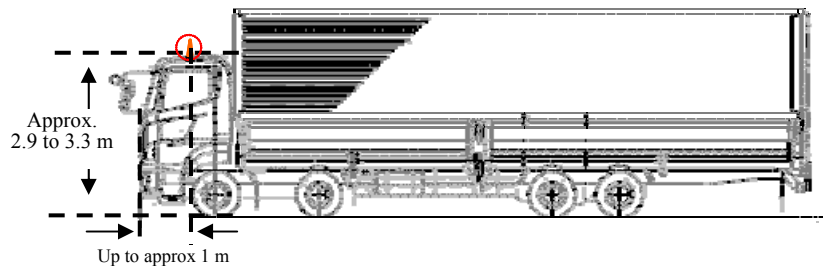

Appendix Fig. C.2-2: Large vehicle: 1 m behind the front of the vehicle, on the cabin roof

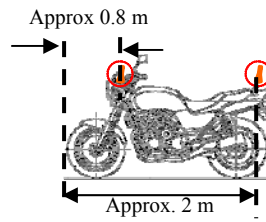

Appendix Fig. C.2-3: Motorcycle: 2 m behind the front of the vehicle front, above the tail lamp

### C.3 Action scenarios in accident-prevention assistance scenes and images of communication areas

The action scenarios in accident prevention-assistance scenes and the images of communication areas considered by ASV-4 are described in the following sections. In the ASV project, the existence or nonexistence of oncoming vehicle from the opposite direction which blocks radio wave is not considered for the right-turn collision prevention system. However, we believe that the communication areas should be considered as described in C.3.2, where the right-turn collision prevention assistance for the failure to judge the speed of the oncoming vehicle in the absence of such oncoming vehicles is considered, and C.3.3, where collision prevention assistance for vehicles that are out of the reach of radio wave because of such oncoming vehicles is considered.

(The ASV-4 concept specifications only indicate the general idea regarding the scenario described in C.3.3, and this scenario is not taken into the consideration in system definitions.)

C.3.1 Left-turn collision prevention system

< Action scenario >

- (1) The non-priority vehicle (NPV), which is going to turn left, receives the information about the priority vehicle (PV, motorcycle) that enters the communication area from behind without reducing its speed.
- (2) After confirming the intention of making a left turn (i.e., after the left-turn indicator is turned on), the NPV provides its driver with collision prevention assistance if the PV is within the communication area where the two vehicles could cross each other when turning left..
- (3) Assistance to the NPV is terminated if the PV has moved into the position ahead of the NPV, if the PV can no longer collide with the NPV making a left turn (i.e., the PV has moved out of the communication area), or if the PV is moving slower than the NPV.

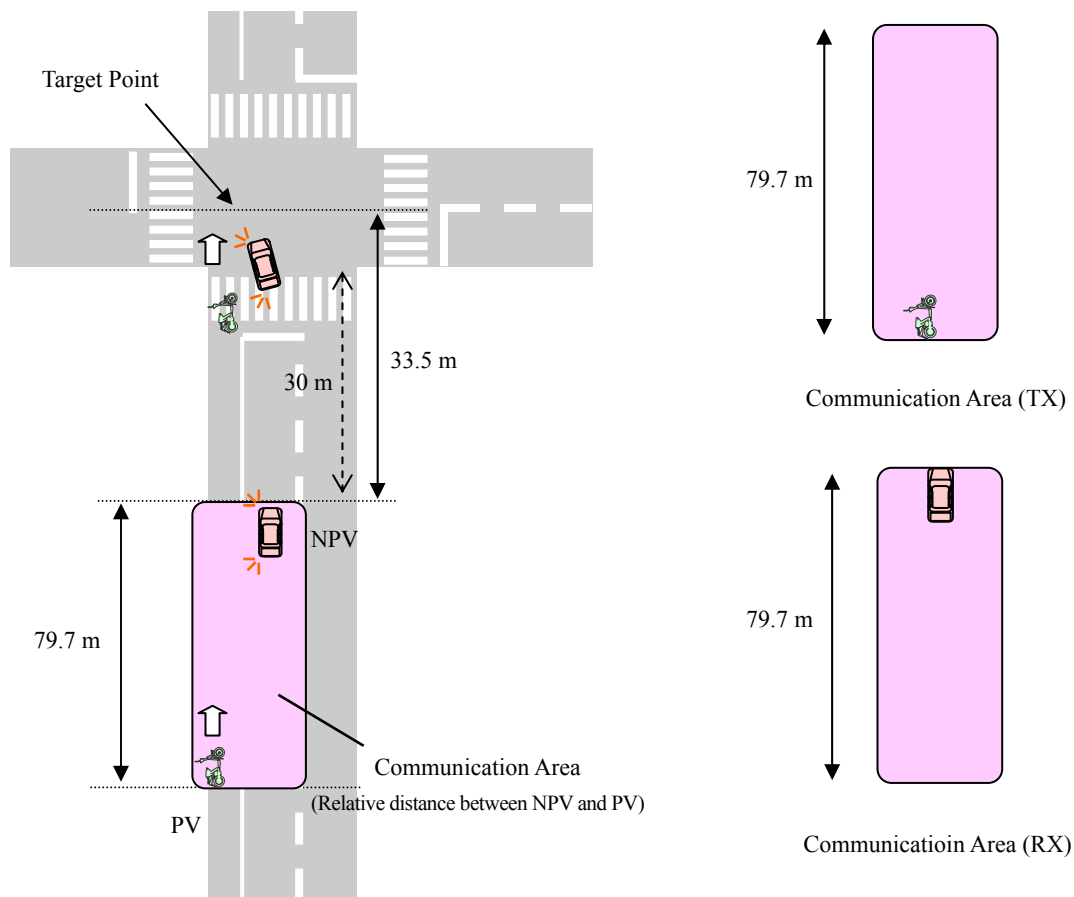

Fig. C.3-1: Communication area for left-turn collision prevention system

C.3.2 Right-turn collision prevention system (without any oncoming vehicle from the opposite direction which blocks radio wave)

< Action scenario >

- (1) The NPV indicates the intention to turn right.
- (2) The NPV receives the information about the oncoming, through-traffic PV.
- (3) If the oncoming, through-traffic PV is within the distance for which the two vehicles could cross each other, information is provided to the driver of the NPV.
- (4) The assistance is terminated as soon as the NPV starts turning right.

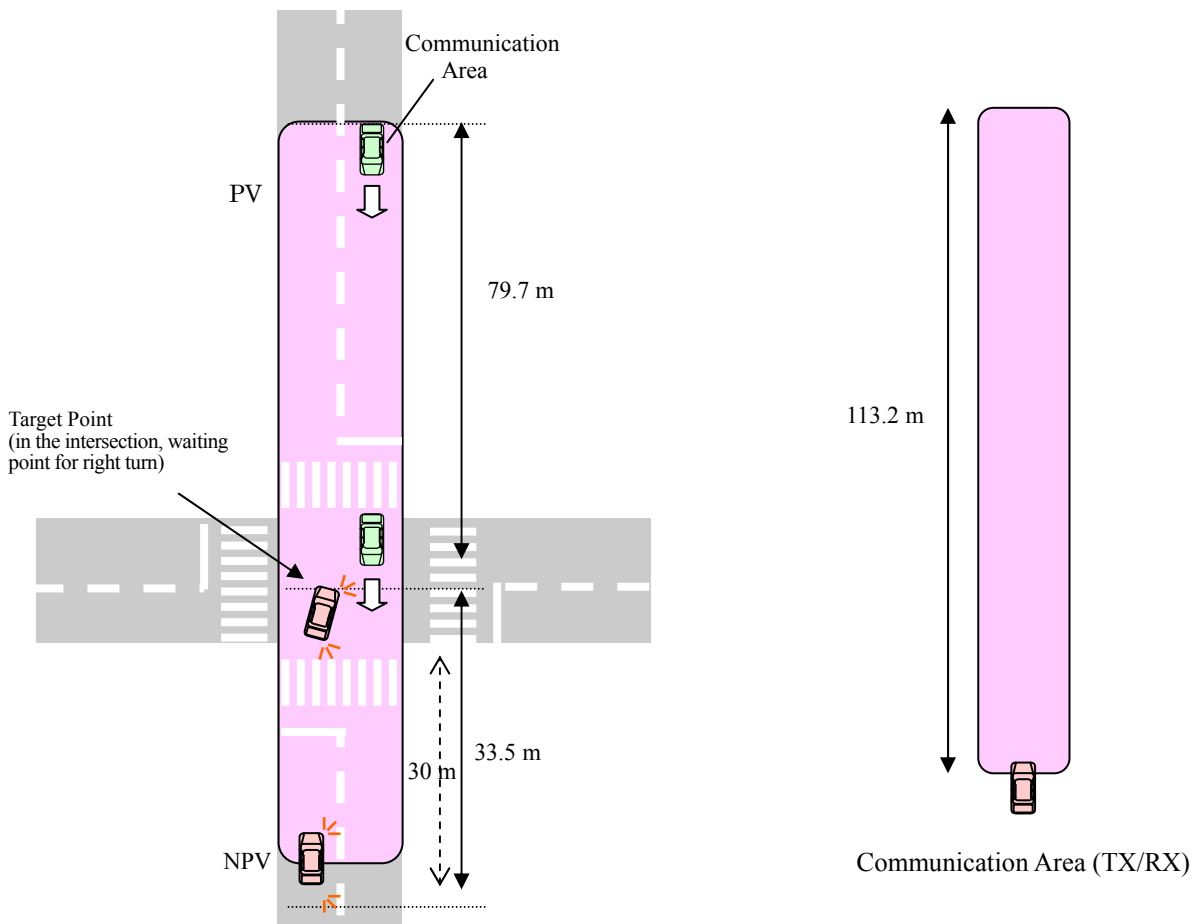
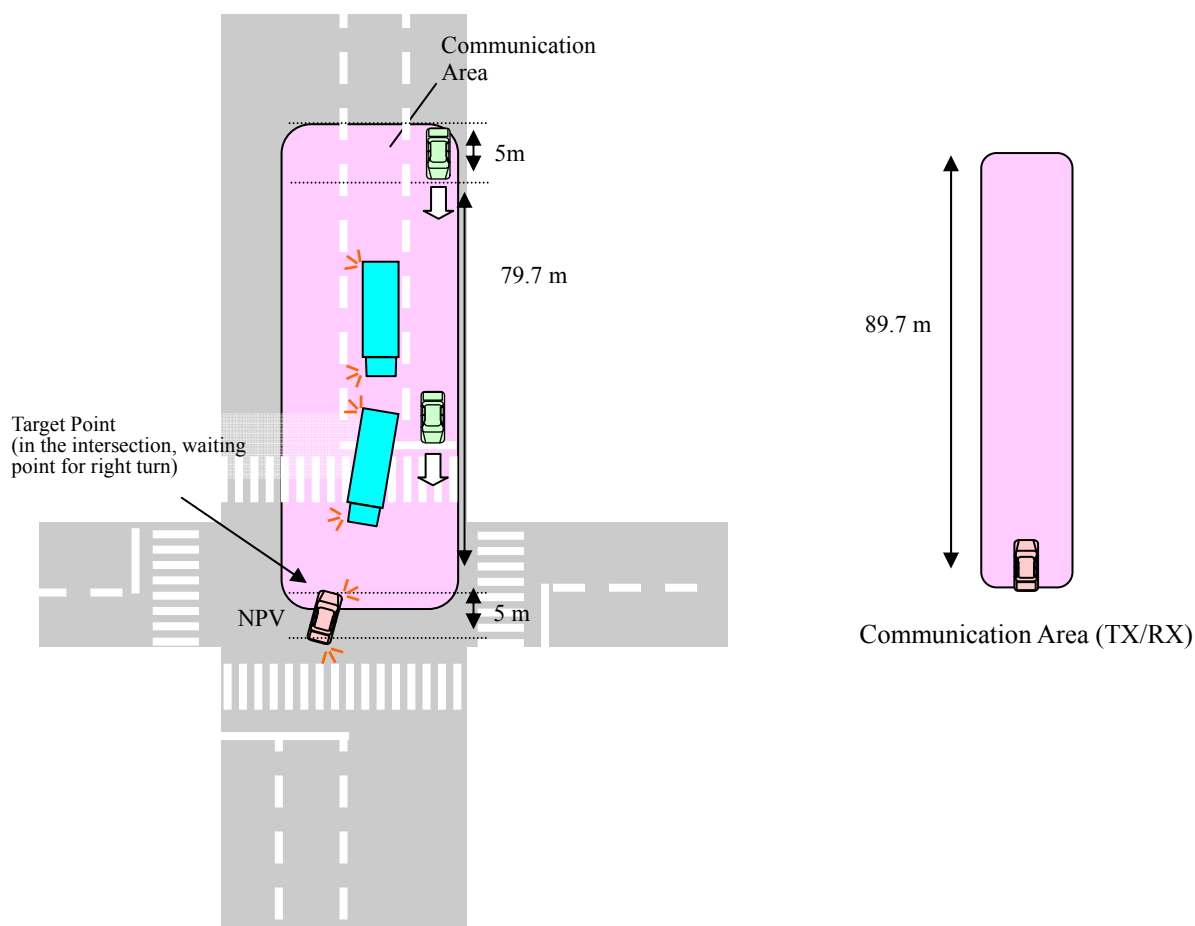

Fig. C3-2: Communication area for right-turn collision prevention system (1)

### C.3.3 Right-turn collision prevention system (with an oncoming vehicle from the opposite direction which blocks radio way)

< Action scenario >

- (1) The NPV is moving toward the intersection.
- (2) The NPV moves into the communication area and can receive information on the oncoming, through-traffic vehicle.
- (3) The received information about the oncoming, through-traffic vehicle is provided when the NPV is determined to have stopped at the intersection for making a right turn; the decision is made on the basis of the status of the NPV, as indicated by the turn indicator, position, vehicle speed, and brake operation.
- (4) The assistance is terminated as soon as the NPV is determined to have started to move; the decision is made on the basis of the status of the NPV, as indicated by the turn indicator, position, vehicle speed, and brake and accelerator operations.



Note: The communication area is calculated as follows: the relative distance between two vehicles when information is first provided (79.7 m) + the antenna distances from the front of the vehicle ( $5 \text{ m} \times 2$ ).

Fig. C.3-3: Communication area for right-turn collision prevention system (2)

## C.3.4 Crossing-collision prevention system (stopping rule not applied to either side)

< Action scenario >

- (1) The NPV is moving toward the intersection of two roads where stopping rule is not applied to either side and both sides have equal priority.
- (2) The NPV moves into the communication area and can receive information about the crossing vehicle.
- (3) The received information about the crossing vehicle is provided when assistance is found to be necessary; the decision is made on the basis of the status of the NPV, as indicated by the position and vehicle speed.
- (4) The assistance is terminated when the NPV is determined to have decelerated to the target vehicle speed before reaching to the presumed crossing point; the decision is made on the basis of the status of the NPV, as indicated by its position and vehicle speed.

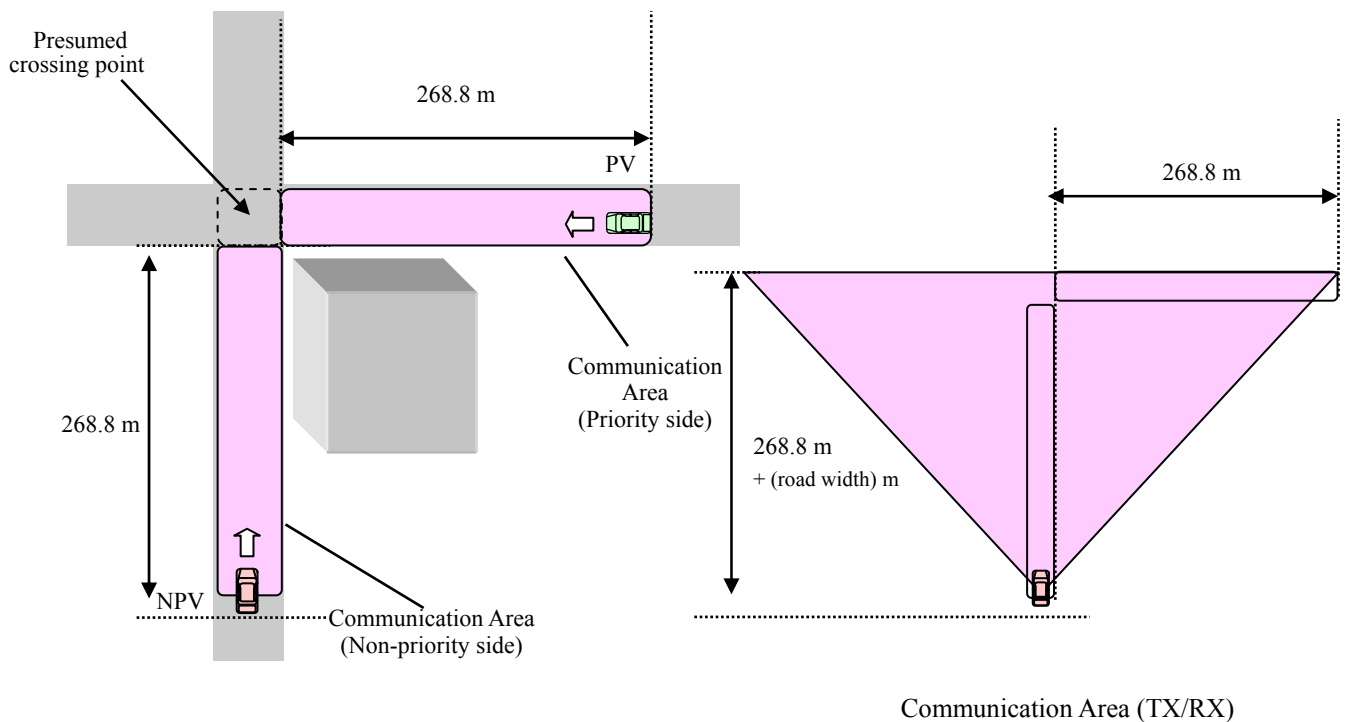

Note: The numerical values in the figure are for large vehicles.  
For ordinary vehicles, 268.8 m is reduced to 174.2 m.

Fig. C.3-4: Communication area for crossing-collision prevention system  
(stopping rule not applied to either side)

C.3.5 Crossing-collision prevention system (stopping rule applied)

< Action scenario >

- (1) The NPV is moving toward the intersection where the stopping rule is applied.
- (2) The NPV moves into the communication area and can receive the information about the crossing vehicle.
- (3) Information about the crossing vehicle begins to be provided when the NPV is determined to have stopped in the vicinity of the halt line; the decision is made on the basis of the status of the NPV, as indicated by its position, vehicle speed, and brake operation.
- (4) The assistance is terminated when the NPV is determined to have started; the decision is made on the basis of the status of NPV, as indicated by its position, vehicle speed, and brake and accelerator operation.

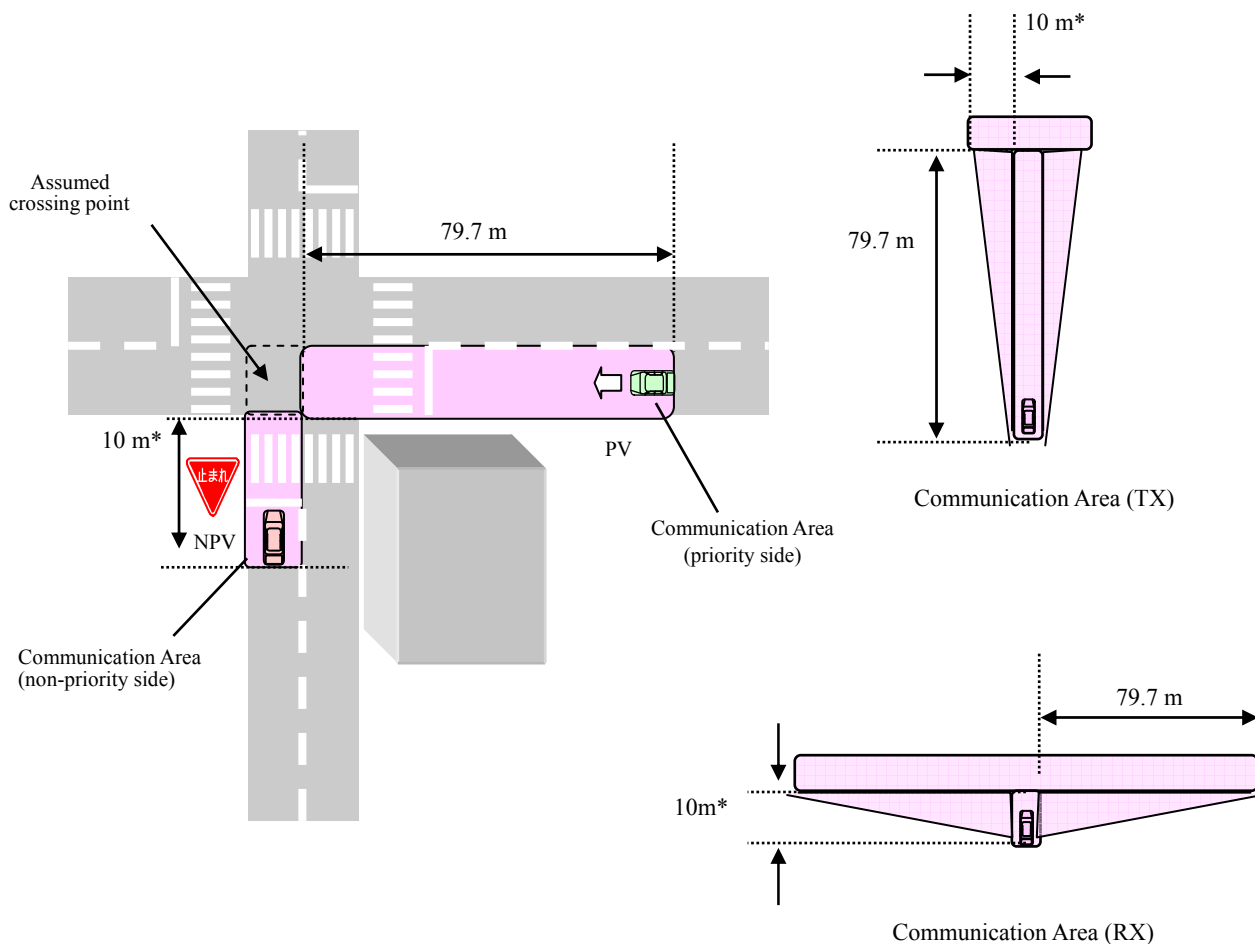

\* The distance "10 m" on the NPV side is set by assuming that the halt line is 5 m behind the line of the view-blocking building wall, and the antenna is located on the roof 5 m behind the front of the vehicle when the vehicle has stopped at that halt line.

Fig. C.3-5: Communication area for crossing-collision prevention system  
(stopping rule applied to both sides)

### C.3.6 Rear-end crash prevention system

< Action scenario >

- (1) The NPV approaches a PV that is moving slowly or has stopped in the same lane from behind.
- (2) The NPV receives vehicle information from the PV, and assistance is provided to the NPV driver.
- (3) The NPV driver reduces the speed while the PV continues to move at a low speed or remain stationary.
- (4) The NPV assistance is continued till the time of assistance termination is confirmed, at which point the assistance is terminated.

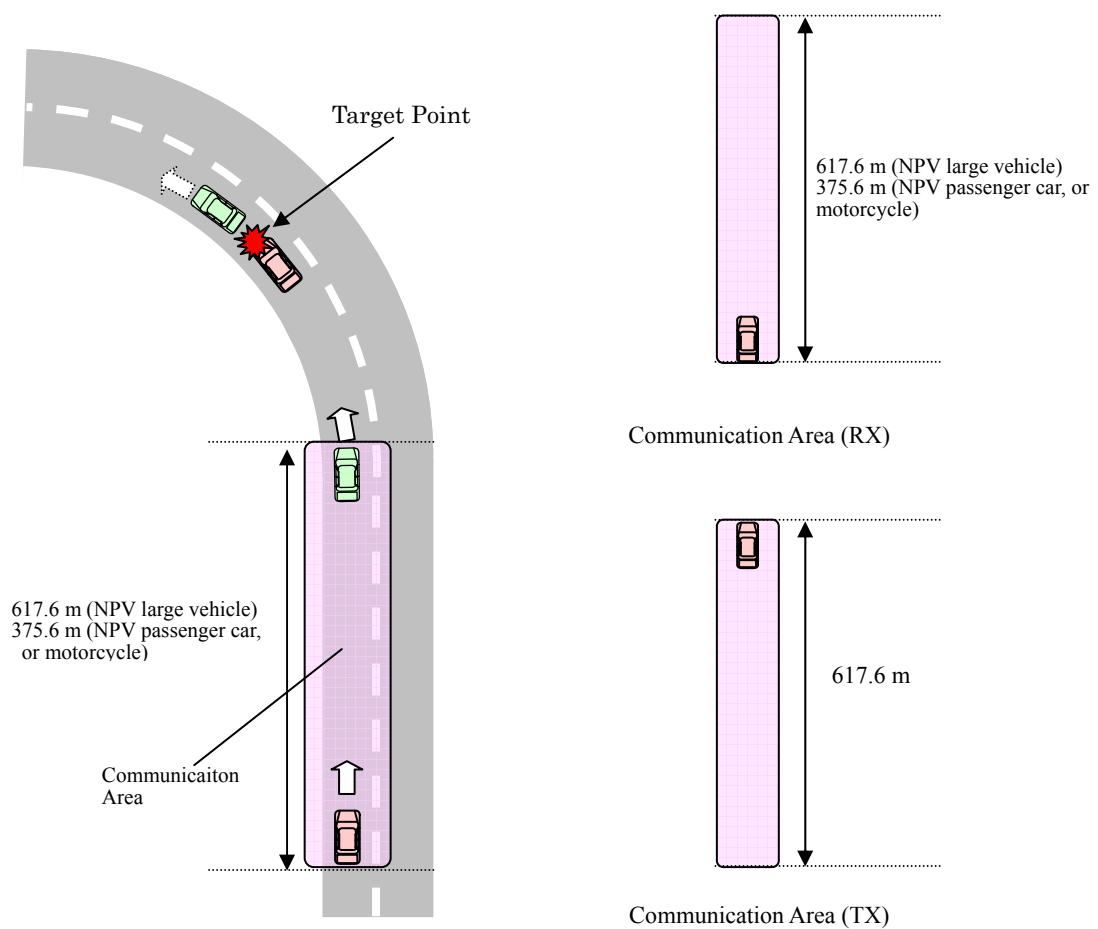

Fig. C.3-6: Communication area for rear-end crash prevention system (on the highway)

## C.3.7 Emergency-vehicle information provision system

## &lt; Action scenario &gt;

- (1) The emergency vehicle is responding to an emergency and moving with its siren blaring while simultaneously sending out communication data containing information on emergency vehicle identification to the other vehicles around it.
- (2) Other vehicles move into the communication area of the emergency vehicle and are able to receive the information about the emergency vehicle.
- (3) Other vehicles may start assistance when the direct distance to the emergency vehicle is less than  $L$  m.
- (4) The assistance is terminated when the direct distance to the emergency vehicle is more than  $L$  m or when it is determined that the assistance is not required.

The communication area of the emergency vehicle has been specified as the area within a radius of  $L = 300$  m around the emergency vehicle; this distance is adopted from the requirement “The warning lamp shall be red, and its light shall be recognizable from a distance of 300 m from the lamp” (laws and regulations by The Ministry of Land, Infrastructure and Transport).

Obstacles and blockades, which may block the radio transmission, are not taken into consideration.

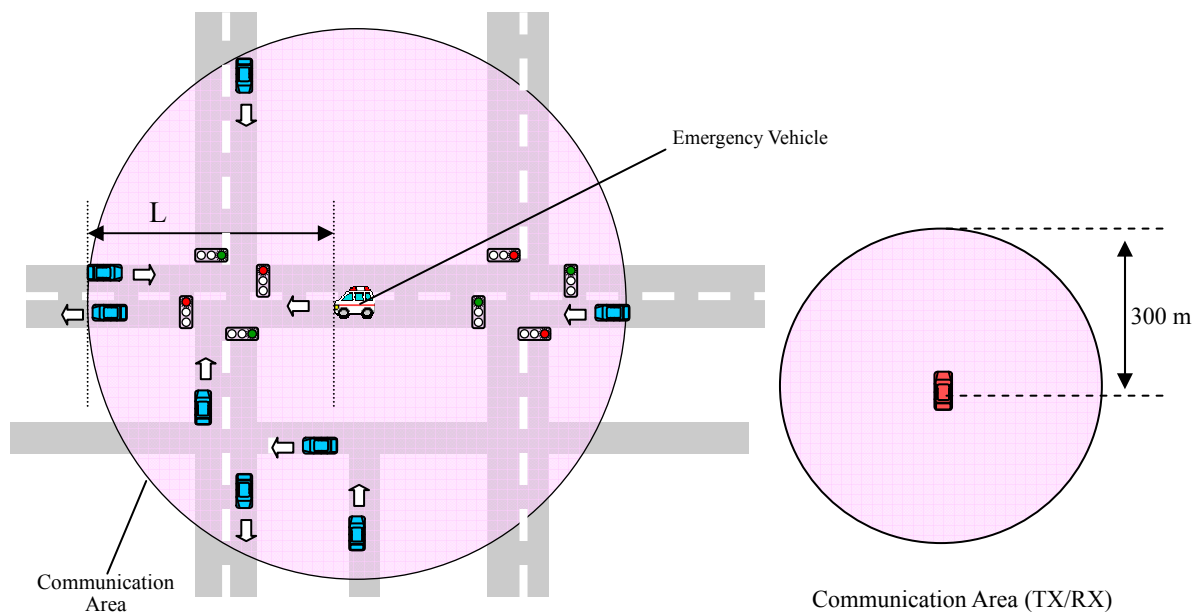

Fig. C.3-7: Communication area for emergency-vehicle information provision system